



INSTALLATION INSTRUCTIONS

<u>Product</u> 7160-1135 GETAC ZX70 CRADLE	<u>Revision</u> A	<u>Form</u> INST-865 Printing Spec: PS-004
--	-----------------------------	---

This instruction sheet is for the Getac ZX70 cradle only. For instructions on features, set-up, and operation of the computer, please refer to the manual provided by Getac with the computer.

This cradle is designed to be used with a variety of Gamber-Johnson mounting systems. Installation instructions for other Gamber-Johnson products are provided with each individual product.

This instruction sheet is for the following products:

Item No. 7160-1135-00
7160-1135-01

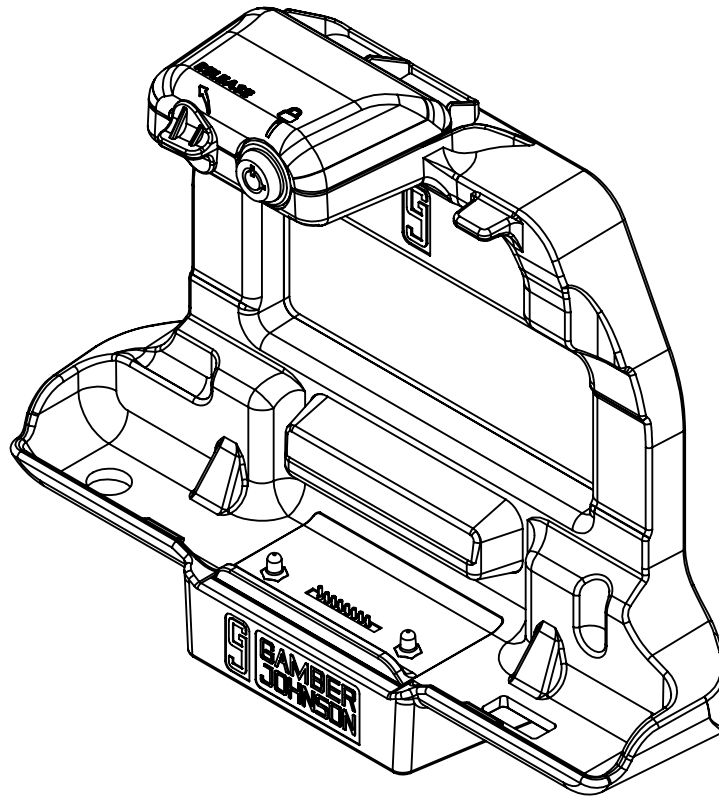

Product Mounting Disclaimer

Gamber-Johnson is not liable under any theory of contract or tort law for any loss, damage, personal injury, special, incidental or consequential damages for personal injury or other damage of any nature arising directly or indirectly as a result of the improper installation or use of its products in vehicle or any other application. In order to safely install and use Gamber-Johnson products full consideration of vehicle occupants, vehicle systems (i.e., the location of fuel lines, brakes lines, electrical, drive train or other systems), air-bags and other safety equipment is required. Gamber-Johnson specifically disclaims any responsibility for the improper use or installation of its products not consistent with the original vehicle manufacturers specifications and recommendations, Gamber-Johnson product instruction sheets, or workmanship standards as endorsed through the Gamber-Johnson Certified Installer Program.

© Copyright 2018 Gamber-Johnson, LLC

If you need assistance or have questions, call Gamber-Johnson at 1-800-456-6868

PRE-INSTALLATION RECOMMENDATIONS

Conduct a "Bench Test" (7160-1135-01)

Gamber-Johnson strongly advises a "bench test" be conducted to verify all electronic and software issues are resolved prior to installation:

1. Make sure the computer is operational by itself.
2. Insert computer into the docking station and verify that the computer is operating in the dock.
3. Interconnect entire assembly and verify start-up of all components, including other equipment (printers, modems, scanners, etc.)

Gamber-Johnson recommends positioning of all mounts and equipment in the vehicle prior to the actual install to verify that mounting locations are safe and practical.

IMPORTANT SAFETY INFORMATION FOR INSTALLERS

Safety is dependent on the proper installation and servicing of this charging cradle. It is important to read and follow all instructions before installing this product.

To properly install a Gamber-Johnson charging cradle you must have a good understanding of automotive electrical procedures and systems, along with proficiency in the installation and service of aftermarket vehicle equipment.

There are no adjustments required at any time of the electrical components within the charging cradle. **Opening the charging cradle will void the product warranty.**

During Installation:

DO NOT connect this charging cradle to the vehicle battery until:

1. All other electrical connections are made
2. Mounting of all components is complete
3. Verification that no shorts exist in the entire system

DO NOT install equipment or route wires or cords in the deployment path of any air bag.

When drilling into the vehicle, DO make sure that both sides of the surface are clear of anything that could be damaged.

CAUTION: *If wiring is shorted to the frame, high current conductors can cause hazardous sparks resulting in electrical fires or flying molten metal.*

After installation:

Test the charging cradle to ensure that it is working properly.

File these instructions in a safe place and refer to them when performing maintenance or re-installing.

WARNING: *Failure to follow all safety precautions and instructions may result in property damage, serious injury, or death.*

GETAC ZX70 CRADLE FEATURE IDENTIFICATION

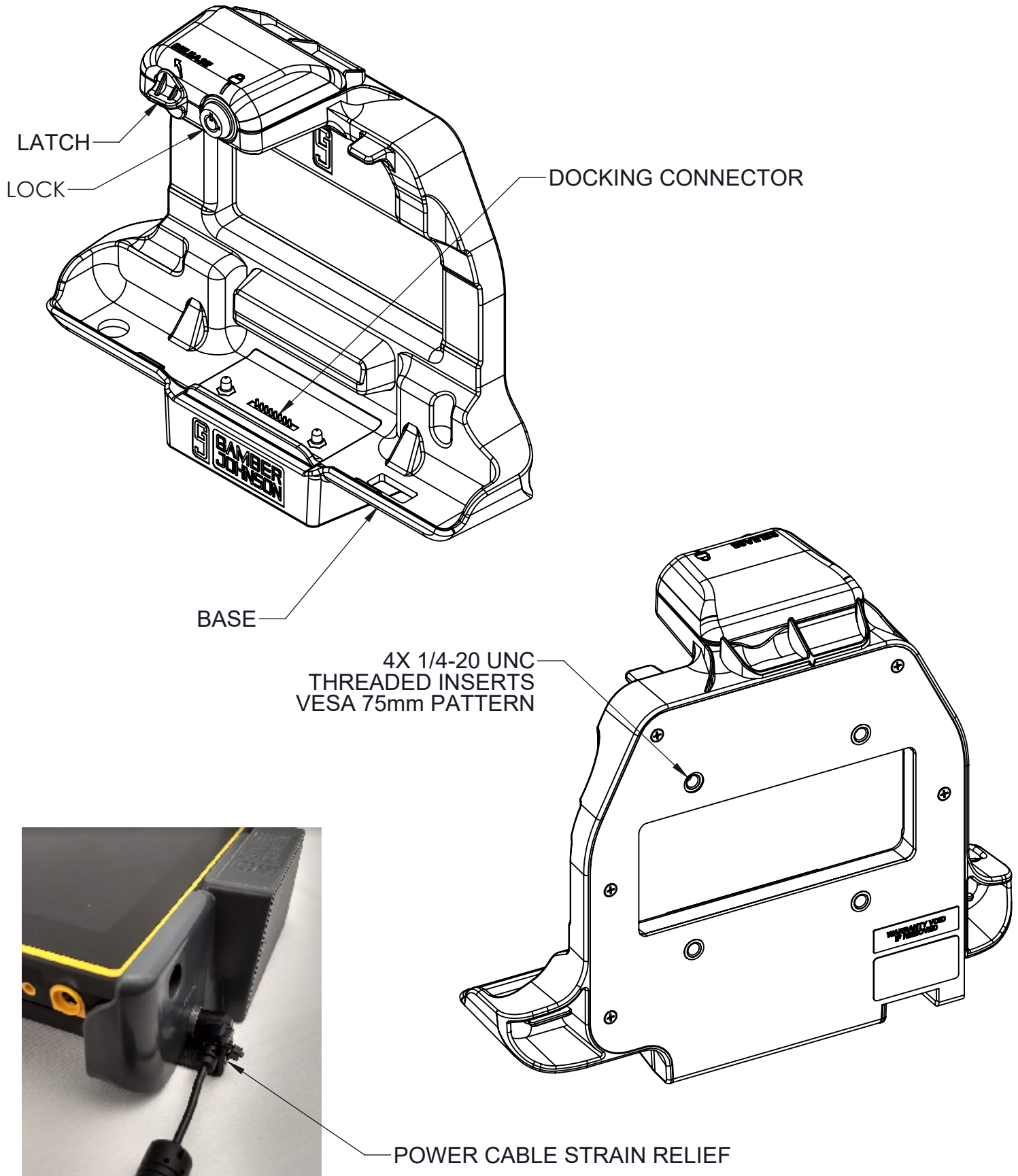

DOCKING AND UNDOCKING THE TABLET

Figure 1



Figure 2



DOCKING THE TABLET

1. Insert the bottom of the tablet into the charging cradle (fig.2)
2. Rotate the top of the tablet back into the cradle until the latch springs down in front of the tablet to hold it in place (fig.3)
3. Optional - The key lock can now be used to secure the tablet in the cradle.

Figure 3



Figure 4



UNDOCKING THE TABLET

1. Unlock if locked
2. Push upward on the thumb knob and pull out on the top of the tablet (fig.4)
3. Lift the tablet out of the dock

REGULATORY CERTIFICATION INFORMATION

Regulatory Model #: 7160-1135

GJ Model #'s & Description:

7160-1135-00 Cradle-Getac-ZX70 (Non-Powered)
7160-1135-01 Cradle-Getac-ZX70 (Power Only)

Certifications:

- EN 50581:2012
- EN 60850-1:2006/A2:2013



Gamber-Johnson LLC, 3001 Borham Ave., Stevens
Point, WI, 54481, USA, 715-344-3482