



Very Well Connected™

# INSTALLATION INSTRUCTIONS

<u>Product</u>	<u>Revision</u>	<u>Form</u>
7160-0403 Flat Floor Semi-Truck Base	Rev. A	INST-556 Printing Spec: PS-001

The 7160-0403 Flat Floor Semi-Truck Base (Fig 1), is a no-drill solution that allows a user to mount workstations, storage or console boxes.

The following instructions describe the installation of the base into an International 4300/7300 truck. The Base can also be installed in other similar sized trucks although drilling of additional mounting holes may be required.

The base and spacer plates mount under both driver and passenger seats. Three locations of strut channel mounting, allows various positioning of equipment.

A 9/16" Socket & Ratchet or Wrench are needed for installation.

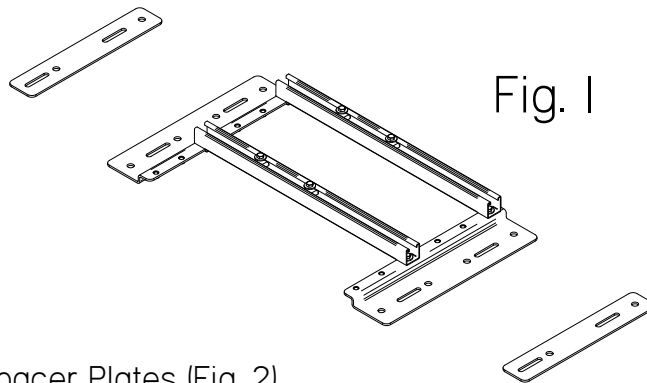

## Mounting the Base and Spacer Plates (Fig. 2)

1. Remove and set aside fasteners securing passenger seat to floor of truck.
2. Tip passenger seat toward outside of truck, install base plate between floor and seat base. Place base plate over two seat mounting studs, with the step portion toward center of truck. Lower seat on to base plate.
3. Tip passenger seat toward center of truck, install spacer plate between floor and seat base. Place spacer plate over two seat mounting studs. Lower seat on to spacer plate.
4. Install base and spacer plates under driver seat by repeating steps 1-4 on driver side seat.
5. Reinstall fasteners securing seats to floor.

### Product Mounting Disclaimer

Gamber-Johnson is not liable under any theory of contract or tort law for any loss, damage, personal injury, special, incidental or consequential damages for personal injury or other damage of any nature arising directly or indirectly as a result of the improper installation or use of its products in vehicle or any other application. In order to safely install and use Gamber-Johnson products full consideration of vehicle occupants, vehicle systems (i.e., the location of fuel lines, brakes lines, electrical, drive train or other systems), air-bags and other safety equipment is required. Gamber-Johnson specifically disclaims any responsibility for the improper use or installation of its products not consistent with the original vehicle manufacturer's specifications and recommendations, Gamber-Johnson product instruction sheets, or workmanship standards as endorsed through the Gamber-Johnson Certified Installer Program.

© copyright 2011 Gamber-Johnson, LLC

If you need assistance or have questions, call Gamber-Johnson at 1-800-456-6868

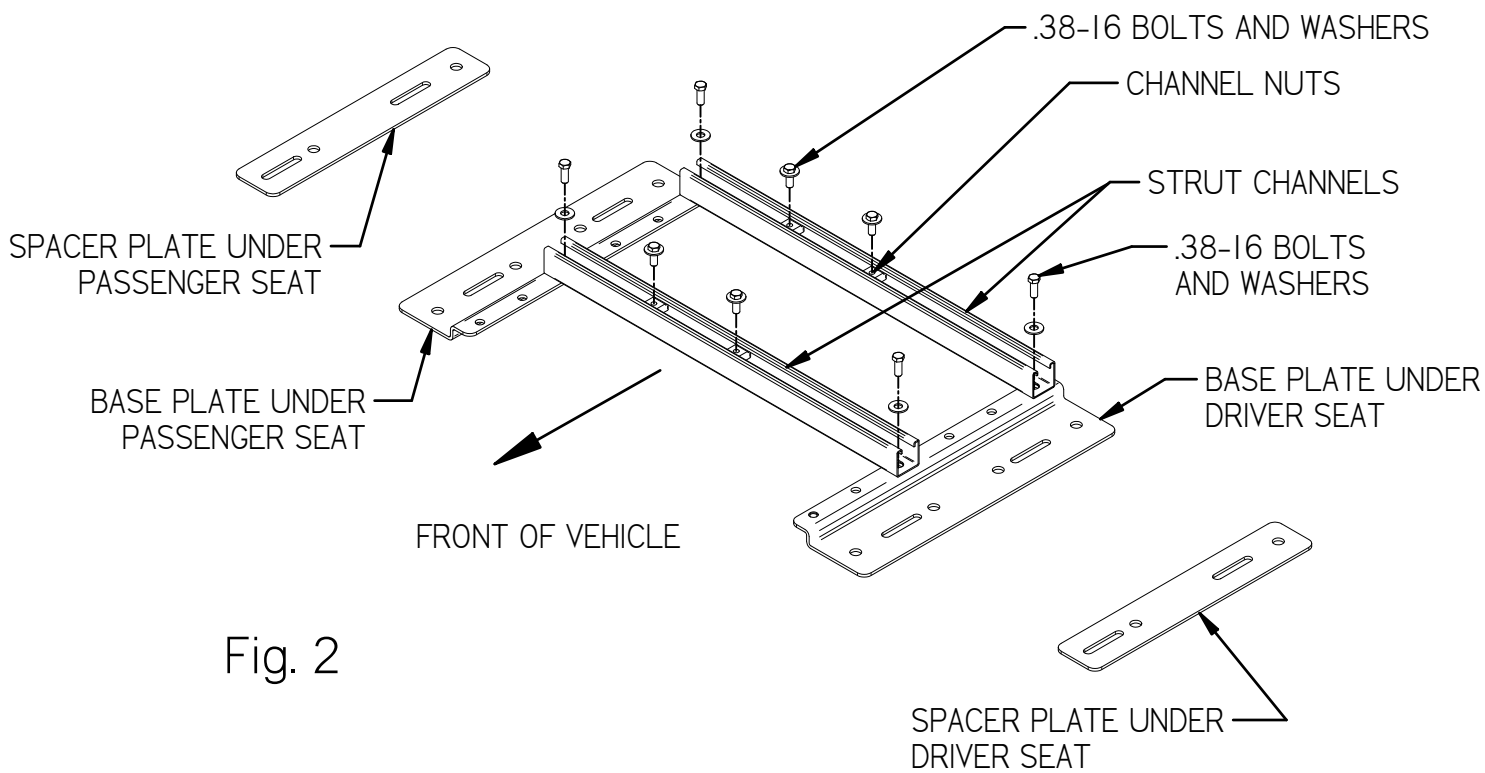

Fig. 2

### Mounting the Workstation, Storage or Console Box (Fig. 2 & Fig. 3)

1. Determine location of equipment between driver and passenger seats. Bolt strut channels to base plates accordingly, using (4) .38-16 bolts and washers, supplied in hardware bag. Position strut channels to line-up with mounting holes in equipment.
2. Place (4) .38-16 channel nuts, supplied in hardware bag, in strut channel and bolt equipment in place using (4) .38-16 bolts and washers.

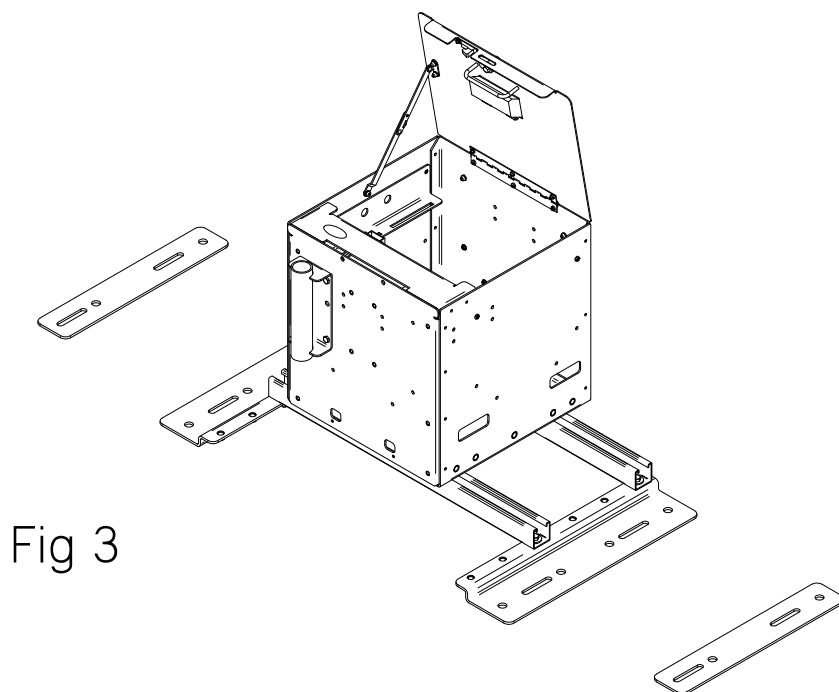

Fig 3