



INSTALLATION INSTRUCTIONS

Product

7170-0974, 7160-1761

Revision

Rev A

Form

INST-1121

PASSENGER PARTITION, FORD PIU, 2020+

Printing Spec: PS-005

WARNING: Locate all wiring, fuel, brake, coolant & refrigerant lines before drilling any holes or installing any self-drilling fasteners.

VEHICLE FRONT →

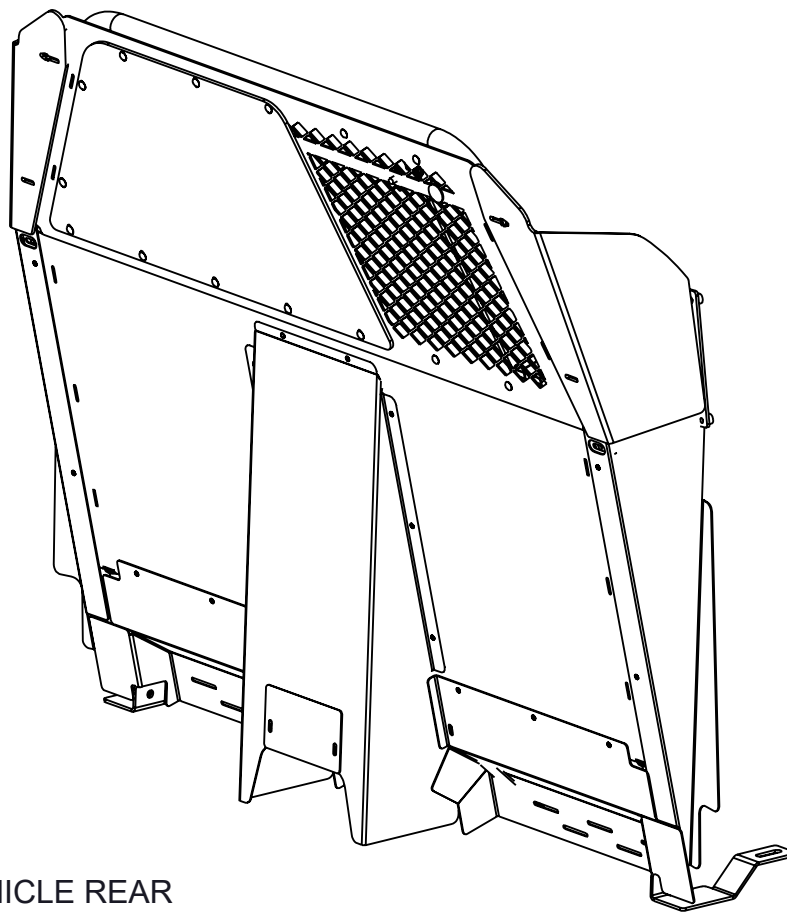

← VEHICLE REAR

Product Mounting Disclaimer

Gamber-Johnson is not liable under any theory of contract or tort law for any loss, damage, personal injury, special, incidental or consequential damages for personal injury or other damage of any nature arising directly or indirectly as a result of the improper installation or use of its products in vehicle or any other application. In order to safely install and use Gamber-Johnson products full consideration of vehicle occupants, vehicle systems (i.e., the location of fuel lines, brake lines, electrical, drive train or other systems), air-bags and other safety equipment is required. Gamber-Johnson specifically disclaims any responsibility for the improper use or installation of its products not consistent with original vehicle manufactures specifications and recommendations, Gamber-Johnson product instruction sheets, or workmanship standards as endorsed through the Gamber-Johnson Certified Installer Program.

© Copyright 2020 Gamber-Johnson, LLC

If you need assistance or have questions, call Gamber-Johnson at 1-800-456-6868

ITEM	QTY	PartNo	DESCRIPTION
1	1	20763-1	PARTITION, MAIN WELDMENT
2	2	20763-3	SLIDE RAIL, WINDOW, PASSENGER PARTITION
3	1	20436	PLATE MOUNT- RETRACTABLE SPRING PLUNGER
4	1	20763-4	SLIDING WINDOW, PASSENGER PARTITION
5	1	20763-2	WINDOW, PASS PARTITION, FIXED
6	1	20778-06	D.S. POLY WING, PASSENGER PARTITION, FORD PIU 20+
7	1	20778-14	D. S. B-PILLAR BRACKET, PASSENGER PARTITION, FORD PIU 20+
8	1	20778-05	P.S. POLY WING, PASSENGER PARTITION, FORD PIU 20+
9	1	20778-13	P. S. B-PILLAR BRACKET, PASSENGER PARTITION, FORD PIU 20+
10	1	20778-10	D.S. LOWER WING, PASSENGER PARTITION, FORD PIU 20+
11	2	20778-16	COVER PLATE, PIU GARMENT HANGER
12	2	20778-15	LOWER TUBE WELDMENT, PASSENGER PARTITION, FORD PIU 20+
13	1	20778-03	D.S. FOOT WELL, PASSENGER PARTITION, FORD PIU 20+
14	1	20778-09	P.S. LOWER WING, PASSENGER PARTITION, FORD PIU 20+
15	1	20778-01	PASSENGER PARTITION, CENTER EXTENSION, FORD PIU 20+
16	1	20778-12	D. S. OUTER BRACKET, PASSENGER PARTITION, FORD PIU 20+
17	1	20778-04	PLATE, WIRE TUNNEL COVER, PASSENGER PARTITION, FORD PIU 20+,
18	1	20778-08	BRACKET, P. S. INNER, PASSENGER PARTITION, FORD PIU 20+
19	1	20778-07	BRACKET, D. S. INNER, PASSENGER PARTITION, FORD PIU 20+
20	1	20778-02	P.S. FOOT WELL, PASSENGER PARTITION, FORD PIU 20+
21	1	20778-11	P. S. OUTER BRACKET, PASSENGER PARTITION, FORD PIU 20+
22	1	7120-1021	HARDWARE BAG-PASSENGER PARTITION

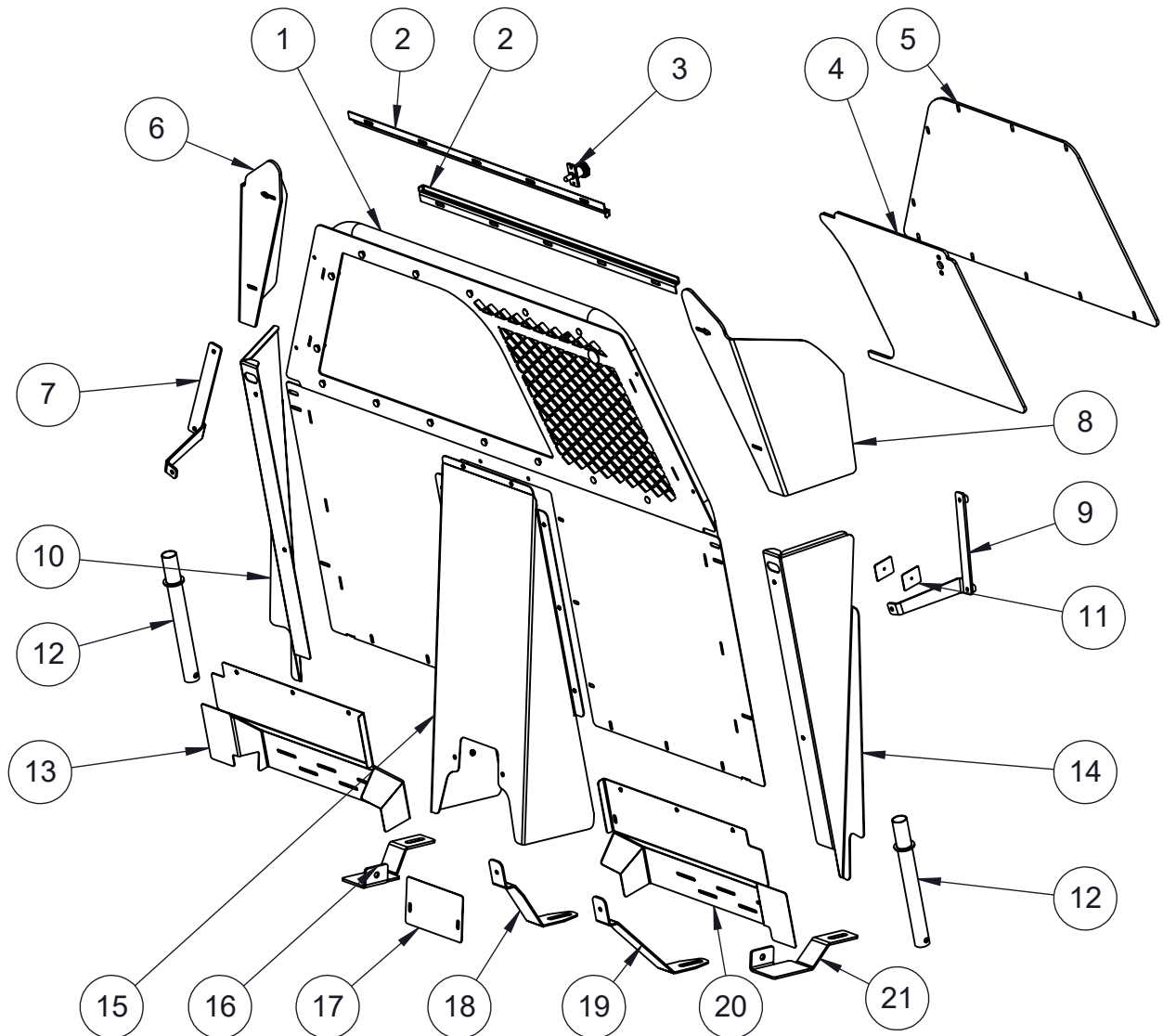

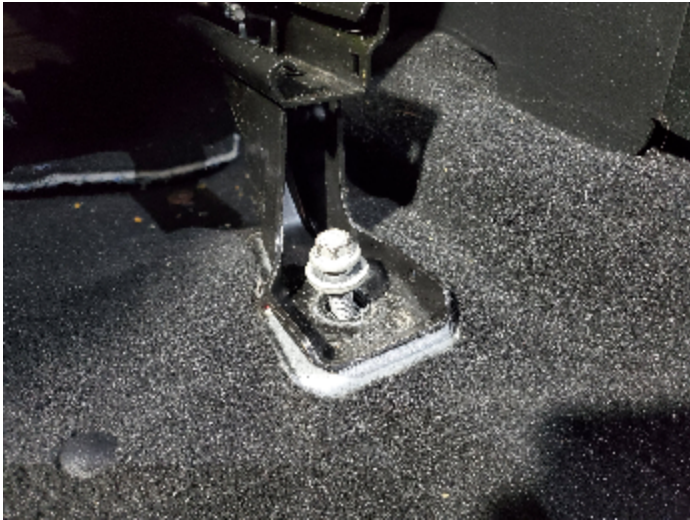

Fig. 1



Fig. 2

1. Slide & lean both front seats fully forward.
2. Remove rear seat bolts (Fig. 1) from both seats. Then, while pivoting the seat forward, slide Passenger & Driver Side Inner and Outer Brackets (items 16,18,19,21) under the seat tracks (Fig. 2). Note orientation on sheet 2.
3. Loosely reinstall seat bolts.
4. Loosely mount Lower Tube (item 12) to each of the Passenger & Driver Side Brackets (items 16, 21) using provided 3/8 hardware (Fig. 3).
5. Remove passenger garment hooks by opening cover and removing screw (Fig. 4).
6. Install Cover Plates (item 11) using OEM screws.



Fig. 3

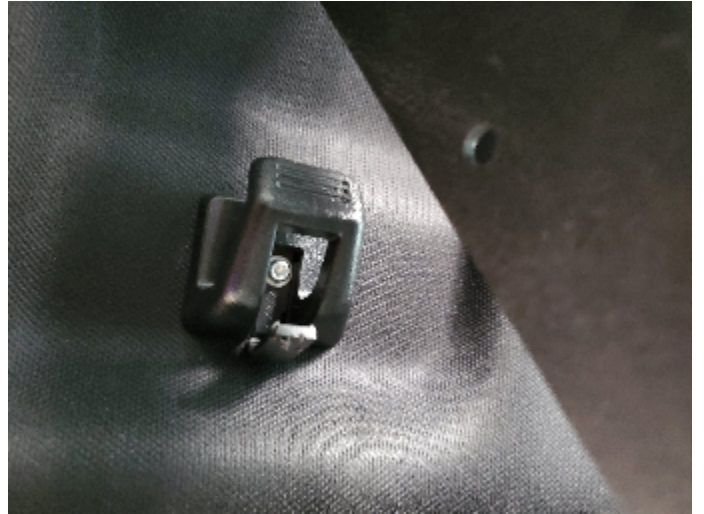

Fig. 4



Fig. 5



Fig. 6

7. Remove cover on b-pillar grab handles and remove the two bolts retaining the grab handles (Fig. 5).
8. Install Driver and Passenger side B-Pillar Brackets (items 7, 9) with bolts removed in step 5 (Fig. 6).
9. Place the Partition (item 1) into the vehicle and slide onto Lower Tubes (items 12).
10. Rotate Partition (item 1) up to B-pillar brackets (items 7,9) and loosely secure using 5/16 bolts, washers and nuts (Fig 7).
11. Loosely install Foot Wells (items 13, 20) to Partition using $\frac{1}{4}$ acorn nuts and washers (Fig. 8).



Fig. 7

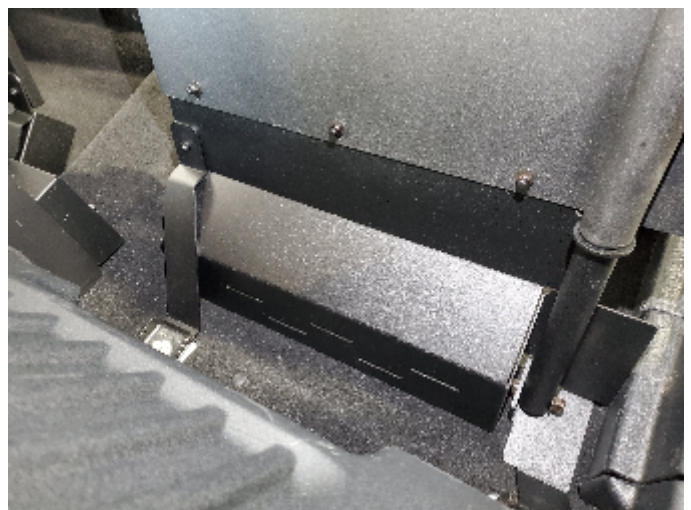

Fig. 8



Fig. 9



Fig. 10

12. Loosely install Lower Wings (items 10,14) to Partition using $\frac{1}{4}$ acorn nuts and washers (Fig. 9 & 10).

13. If vehicle does not have transmission tunnel cable chase, attach Plate, Wire Tunnel cover (item 17) to Center Extension (item 15) using $\frac{1}{4}$ button head screws (Fig. 11).

14. Install Center Extension (item 15) to Partition using $\frac{1}{4}$ acorn nuts and screws (Fig. 12).

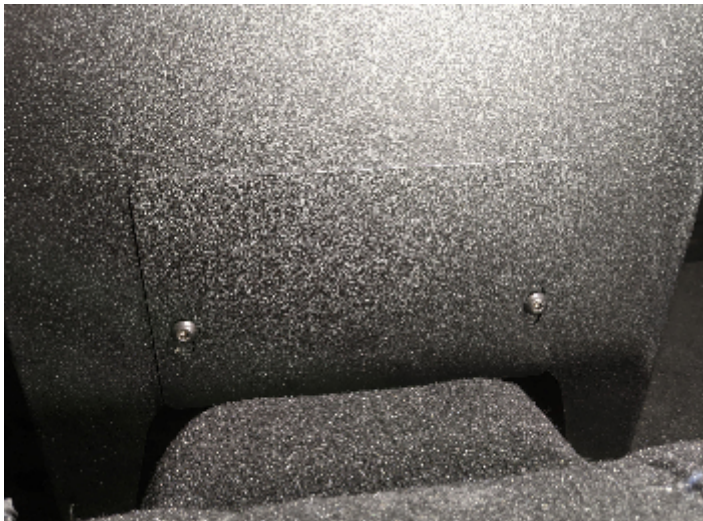

Fig. 11

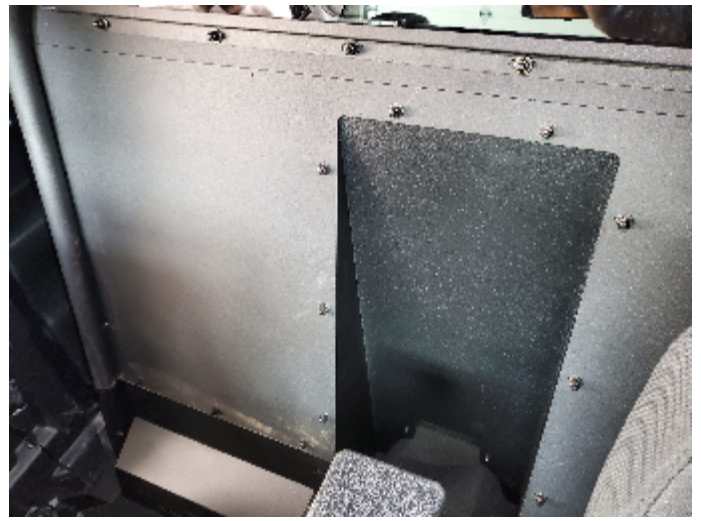

Fig. 12



Fig. 13



Fig. 14

PLASTIC
WASHER

15. Install $\frac{1}{4}$ button head screws to secure Foot Wells (items 13,20) to Inner Brackets (items 18,19) (Fig. 13).
16. Install Poly Wings (items 6,8) to partition using provided $\frac{1}{4}$ button head screws, nylon washers, flat washers and acorn nuts (Fig. 14). Note: Only tighten hardware enough to keep Poly Wing from easily moving. Do not over tighten or Poly Wings could be damaged.
17. Tighten all hardware including OEM seat bolts.
18. Test function of Sliding Window (item 4). Window alignment and stop point can be adjusted if required (items 2).

