



INSTALLATION INSTRUCTIONS

<u>Product</u> 7120-0587 & 7120-0635 NOTEPAD™V & NOTEPAD™V-LT CAM CLIP CONVERSION KIT	<u>Revision</u> Rev.C	<u>Form</u> INST-577 Printing Spec: PS-001
---	---------------------------------	---

This kit contains the components needed to convert the Gamber Johnson Notepad V (7160-0250) and Notepad V-LT (7160-0402) so that they can be used with smaller notebook and tablet format computers, without the bulk of the Rear Support/Brace.

The kit provides a depth adjustment of 7.2 - 8.1 inch when the Cam Mount Clip is installed facing inward and 8.1 - 9 inch when the Cam Mount Clip is installed facing outward.

The width adjustment, 10.62 - 16.50 inch (for Notepad V) and 8.2 - 11.8 inch (for Notepad V-LT) remain unchanged, as does the height adjustment of 0 - 1.5 inch.

7120-0587

A 9/64 inch Hex (Allen) wrench will be needed for installation and adjustment.

7120-0635

A 9/64 inch Pin-in-Hex (Allen) wrench / bit, will be needed for installation and adjustment.

If attached, remove existing Rear Support/Braces from back edge of cradle.
When finished cradle should appear as shown in Fig. 1.

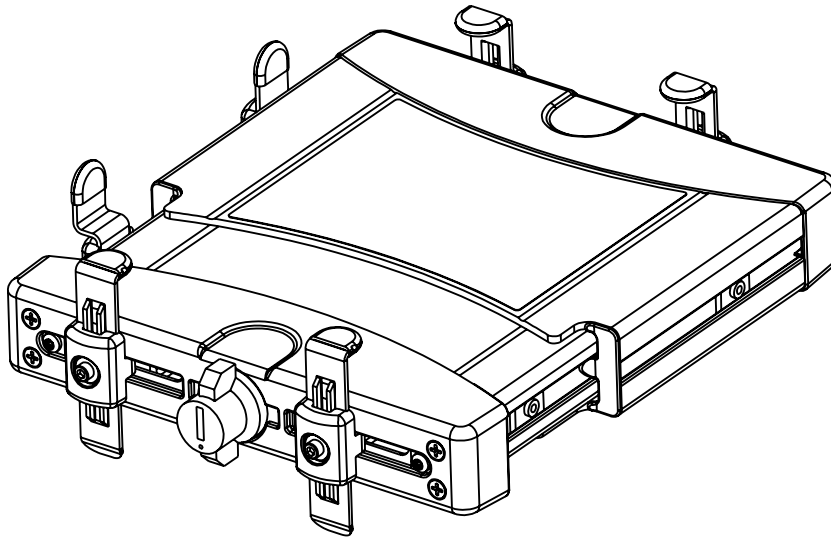

Fig. 1

Product Mounting Disclaimer

Gamber-Johnson is not liable under any theory of contract or tort law for any loss, damage, personal injury, special, incidental or consequential damages for personal injury or other damage of any nature arising directly or indirectly as a result of the improper installation or use of its products in vehicle or any other application. In order to safely install and use Gamber-Johnson products full consideration of vehicle occupants, vehicle systems (i.e., the location of fuel lines, brakes lines, electrical, drive train or other systems), air-bags and other safety equipment is required. Gamber-Johnson specifically disclaims any responsibility for the improper use or installation of its products not consistent with the original vehicle manufactures specifications and recommendations, Gamber-Johnson product instruction sheets, or workmanship standards as endorsed through the Gamber-Johnson Certified Installer Program.

© Copyright 2012 Gamber-Johnson, LLC

If you need assistance or have questions, call Gamber-Johnson at 1-800-456-6868

ASSEMBLY

Install components of conversion kit as shown in Fig. 2. Position Cam Mount Clips facing inward (shown) or outward based on depth adjustment range (see page 1) needed for computer/tablet. When completed, cradle should appear as shown in Fig. 3. All screws should be loosely tightened to allow side-to-side movement of Clip Guides and rotation of Cam Clips.

7120-0635

Use security hardware version of screws for the (3) #8 x .625 screws and (1) #8-32 screw. Sizes are still the same as indicated

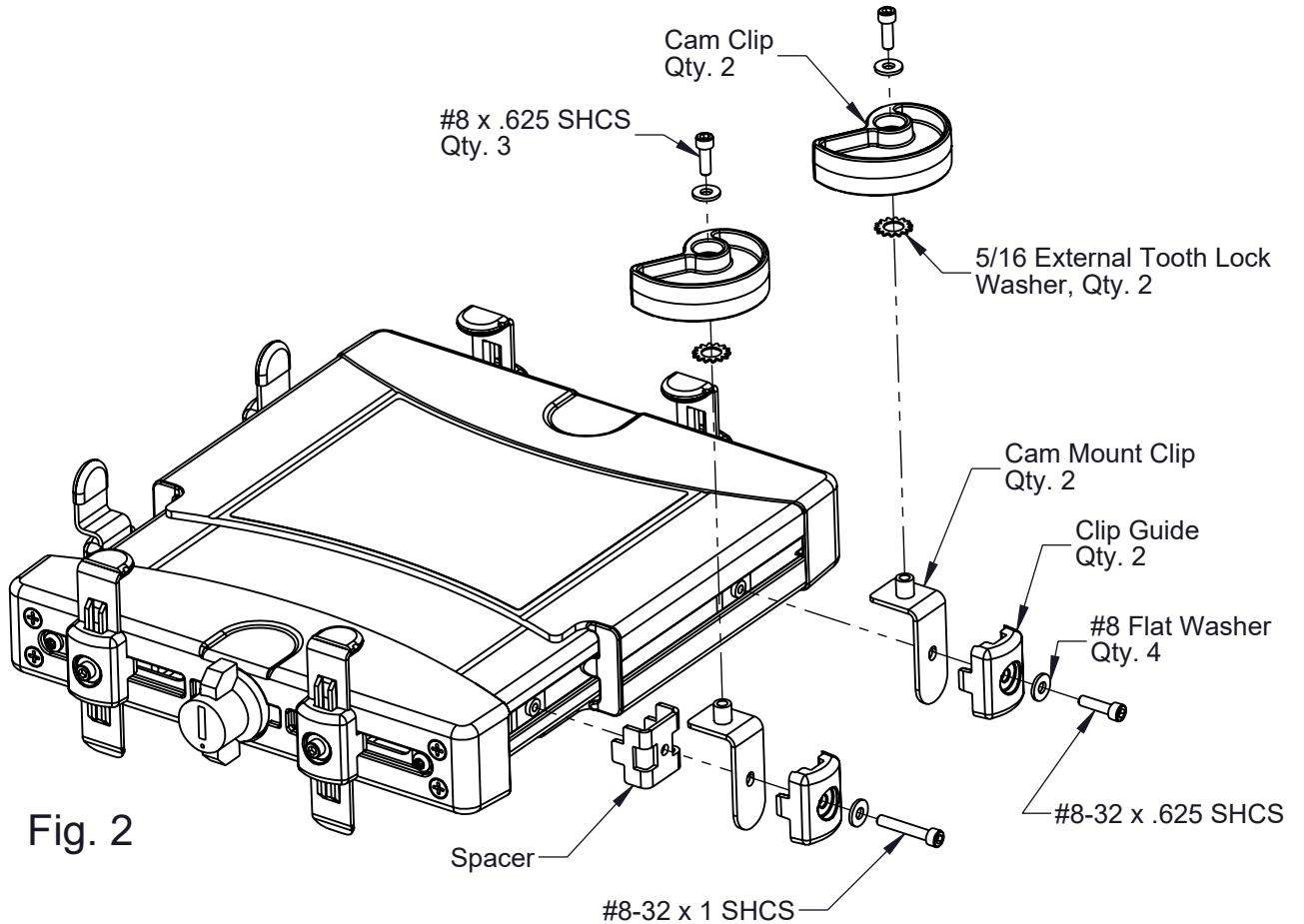

Fig. 2

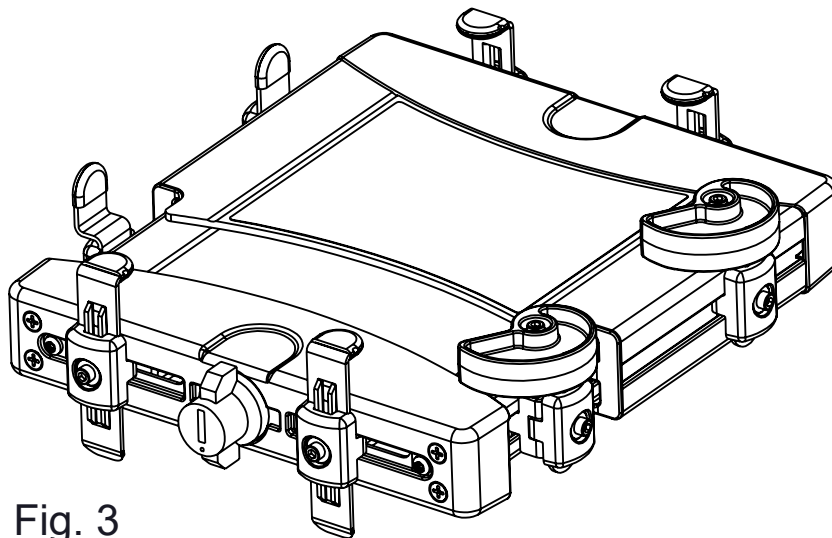

Fig. 3

ADJUSTMENT

If latch on the cradle is locked use key provided to unlock. Pull the lock side of the cradle away from the fixed side to width needed to place computer/tablet on top of cradle. Fig. 4

Loosen adjustment screws securing Front and Side Clips enough to raise them and move them in their slots.

Place the computer/tablet on the cradle. Slide the computer/tablet tight against the Front Clips. Keeping computer/tablet in contact with Front Clips slide it to make contact with Side Clips mounted on fixed side of cradle. Push lock side of cradle towards the fixed side until the Side Clips make contact with the computer//tablet. Turn the latch to secure computer/tablet in cradle. Make sure tabs on Side Clips are above computer/tablet. Fig. 5

Adjust Front Clips side-to-side. When in desired position secure by tightening adjustment screw. Adjust Side Clips side-to-side and up-down. When in desired position secure by tightening adjustment screw.

Do not position Clips over vents or desired ports.

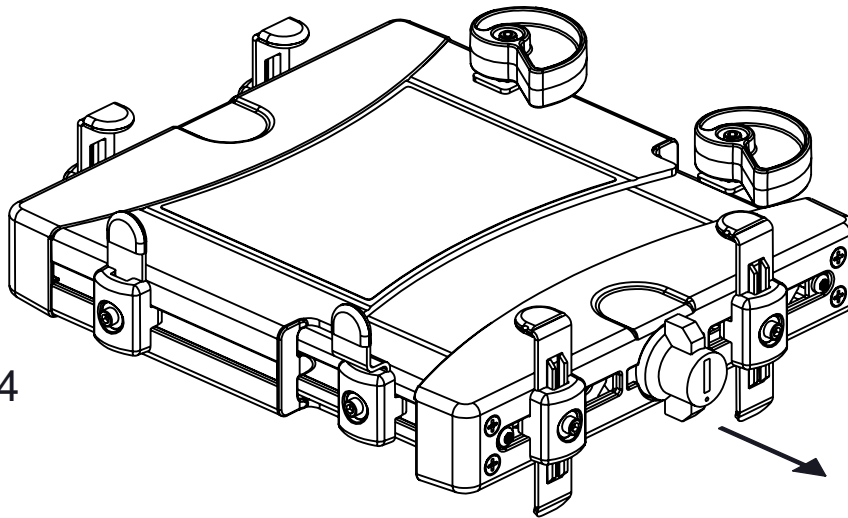

Fig. 4

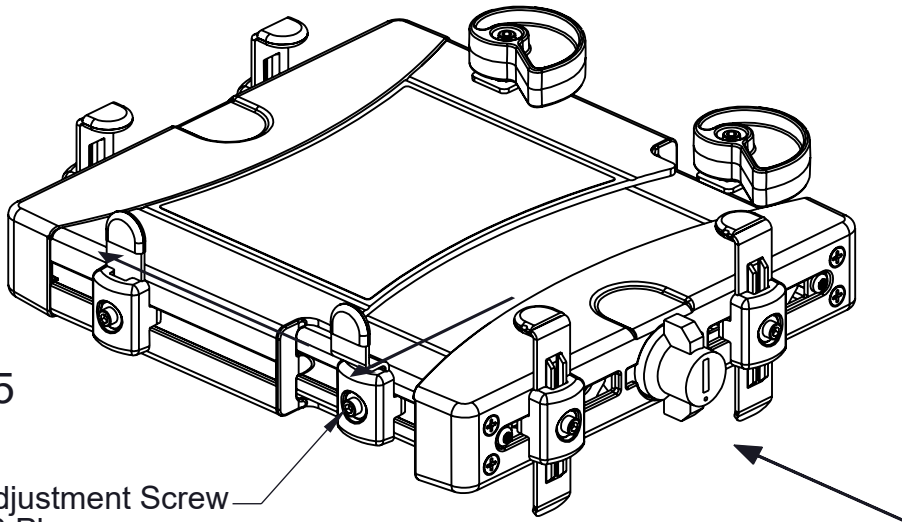

Fig. 5

Adjustment Screw
10 Places

Slide Clip Guides side-to-side.
When in desired position secure by tightening adjustment screw.
Rotate Cam Clip until making contact with computer/tablet.
When making contact in desired location secure by tightening adjustment screw.

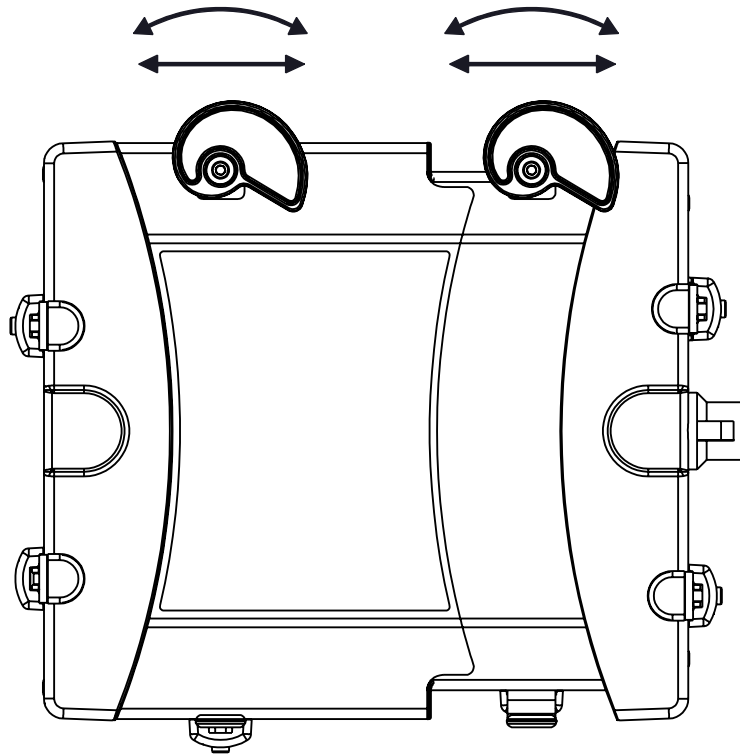

Fig. 6