



INSTALLATION INSTRUCTIONS

Product

7140-0001 thru -0999
Single & Double Slot Faceplates

Revision

Rev A

Form

INST-3

Printing Spec: PS-001

ASSEMBLING MCS FACEPLATES: (Refer to figure 1)

1. Check that the following pieces are present:

- (1) faceplate vertical offset
- (1) faceplate top bracket
- (1) flat washer #6
- (1) 6-32 nut

2. For each faceplate, slide the faceplate vertical offset (item 1) on the stud in the faceplate top bracket (item 2).

Add flat washer (item 3) and hex nut (item 4). Remove the extra strips of dual lock fastener pressed onto each console box under holddown rails, cut to same length as each faceplate, remove the protective film covering the adhesive strip and apply to the top bracket as shown.

3. If the faceplates are being mounted in an older style MCS Console Box, those with threaded inserts on the top surface of the side panels, (holddown screws passing through slots in existing faceplates or blank panels), DO NOT attach the strip of dual lock fastener on each faceplate as described above.

When installing faceplates into these MCA Console Boxes, mark any that cover the threaded inserts and drill a .312" diameter clearance hole as shown in Figure 1.

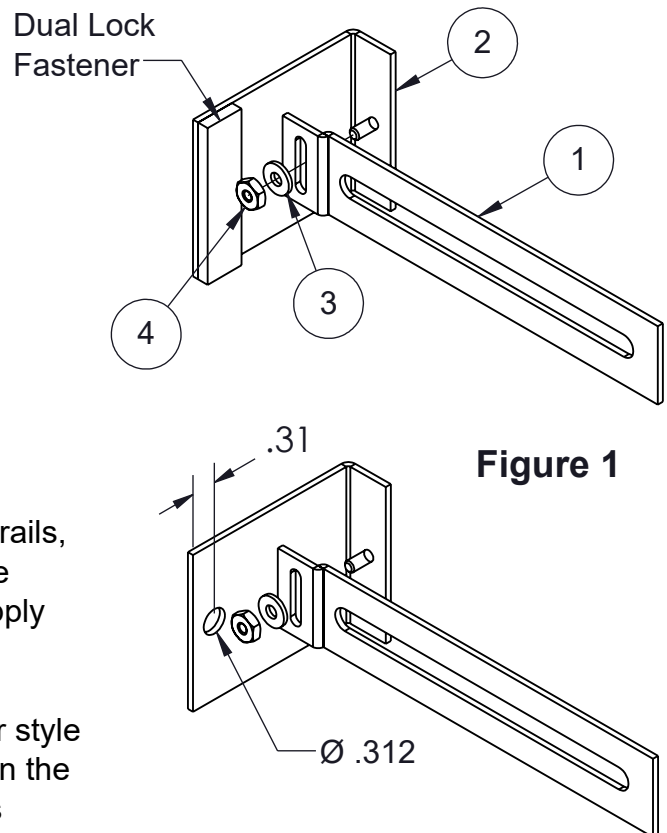

Figure 1

Product Mounting Disclaimer

Gamber-Johnson is not liable under any theory of contract or tort law for any loss, damage, personal injury, special, incidental or consequential damages for personal injury or other damage of any nature arising directly or indirectly as a result of the improper installation or use of its products in vehicle or any other application. In order to safely install and use Gamber-Johnson products full consideration of vehicle occupants, vehicle systems (i.e., the location of fuel lines, brake lines, electrical, drive train or other systems), air-bags and other safety equipment is required. Gamber-Johnson specifically disclaims any responsibility for the improper use or installation of its products not consistent with original vehicle manufactures specifications and recommendations, Gamber-Johnson product instruction sheets, or workmanship standards as endorsed through the Gamber-Johnson Certified Installer Program.

© Copyright 2022 Gamber-Johnson, LLC

If you need assistance or have questions, call Gamber-Johnson at 1-800-456-6868

ASSEMBLING MCS FACEPLATES TO CONTROL HEADS AND INSTALLING IN MCS CONSOLE BOXES (Refer to figures 2 & 3).

1. Install the faceplates on each control head as shown in figure 2. Adjust the faceplates so the mounting holes in the sides of the control head line up in the slots of the faceplate vertical offsets and so the desired amount of the control head will extend from the console. Make sure to allow enough room underneath for any connectors that may be required. Test fit each control head, the tallest heads may need to be installed near the higher end of the console.

2. Arrange the control heads in the console box as desired. Blank panels of various sizes have been provided to act as spacers between each control head, if needed. Secure in place by attaching a piece of dual lock fastener to each end of the blank panel and then pressing the strips of dual lock fastener on the faceplates, blank panels and console box together.

3. Attach the MCS Console Box holdowns to the sides of the console box and over faceplates with (6) 10-32 x .38 Phillips head machine screws.

