



INSTALLATION INSTRUCTIONS

Product 7160-0248 VEHICLE BASE CHEVROLET EXPRESS VAN (2010+) CHEVROLET G-SERIES VAN (2010+) GMC SAVANA (2010+) GMC G-SERIES VAN (2010+)	Revision Rev E	Form INST-477
		Printing Spec: PS-001

▲ IMPORTANT SAFETY INFORMATION

- You must read and follow all installation instructions. Failure to follow installation instructions may result in death or serious bodily injury.
- Keep these installation instructions with the product and readily available in the vehicle for future reference of other users of the product.
- Additional copies of the installation instructions can be obtained from Gamber Johnson or by scanning the QR code located on the product if available.
- DO NOT position the equipment in front of an airbag. Equipment positioned in front of an airbag can cause serious injury or death when airbag is deployed.
- Disconnect vehicle battery before installation.

1. Attach brace to base gusset as shown with supplied hardware, finger tight. Do not install pad at this time.
2. Remove the 4 nuts securing passenger seat in vehicle and lift seat off the studs.
3. Position your 7160-0248 vehicle base on the inboard set of seat studs.
4. Replace seat and extend brace against seat frame (FIG 1). Make sure the Seat Adjustment Handle clears the mount before moving the seat forward (Fig 2).
5. If desired, the brace may be attached to the seat frame with customer supplied hardware. Mark hole location on seat frame. You will need to remove seat to allow access for drilling.

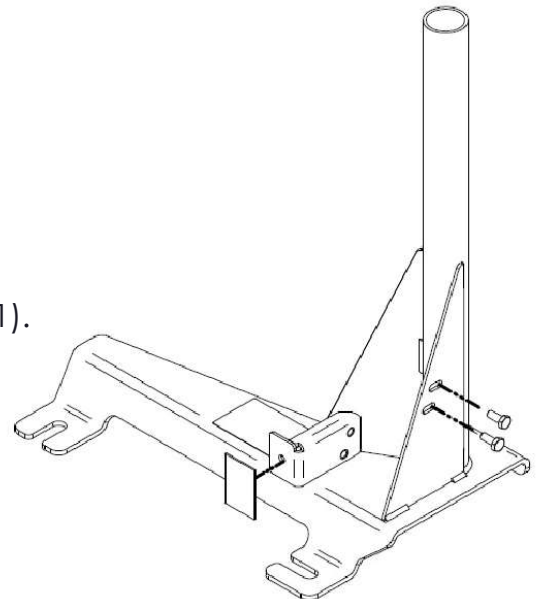

Product Mounting Disclaimer

Gamber-Johnson is not liable under any theory of contract or tort law for any loss, damage, personal injury, special, incidental or consequential damages for personal injury or other damage of any nature arising directly or indirectly as a result of the improper installation or use of its products in vehicle or any other application. In order to safely install and use Gamber-Johnson products full consideration of vehicle occupants, vehicle systems (i.e., the location of fuel lines, brakes lines, electrical, drive train or other systems), air-bags and other safety equipment is required. Gamber-Johnson specifically disclaims any responsibility for the improper use or installation of its products not consistent with the original vehicle manufactures specifications and recommendations, Gamber-Johnson product instruction sheets, or workmanship standards as endorsed through the Gamber-Johnson Certified Installer Program.

© Copyright 2013 Gamber-Johnson, LLC

6. Remove backing and apply pad to brace. If attaching with screw, pierce a hole in the pad after adhering.
7. Replace seat and tighten nuts securing it in the vehicle. Make sure the Seat Adjustment Handle clears the mount before moving the seat forward.
8. If desired, attach brace to seat frame with customer supplied hardware.
9. Pull base pole away from the passenger seat, extend brace against seat base and tighten the two brace screws.
10. Install upper pole, motion attachment and docks/cradle per the instructions supplied with those products.



Fig 1



Fig 2



- The 7160-0248 Assembly should not be positioned in the area where the airbag may be deployed.
- DO NOT position the equipment in front of an airbag. Equipment positioned in front of an airbag may cause serious injury or death if an airbag is activated.
- If installation of the equipment requires that the equipment be placed in front of an airbag, the airbag should be deactivated. In order to secure permission for deactivating the airbag you must contact the National Highway Traffic Safety Administration at 1-800-424-9393 to gain permission to do so. If you have any questions or need assistance, call Gamber-Johnson at 1-800-456-6868.
- High speed vehicle turns may cause parts of the assembly to swivel, interfering with the driver or other equipment.