



# INSTALLATION INSTRUCTIONS

**Product**  
**7160-1332**

**Revision**  
**C**

**Form**  
**INST-879**

**BASE -**  
**CHEVY SILVERADO/GMC SIERRA 2019+/2020+ HD**  
**CHEVY TAHOE PPV/SSV 2021+**

**Printing Spec:PS-001**

## **▲ IMPORTANT SAFETY INFORMATION**

- You must read and follow all installation instructions. Failure to follow installation instructions may result in death or serious bodily injury.
- Keep these installation instructions with the product and readily available in the vehicle for future reference of other users of the product.
- Additional copies of the installation instructions can be obtained from Gamber Johnson or by scanning the QR code located on the product if available.
- DO NOT position the equipment in front of an airbag. Equipment positioned in front of an airbag can cause serious injury or death when airbag is deployed.
- Disconnect vehicle battery before installation.

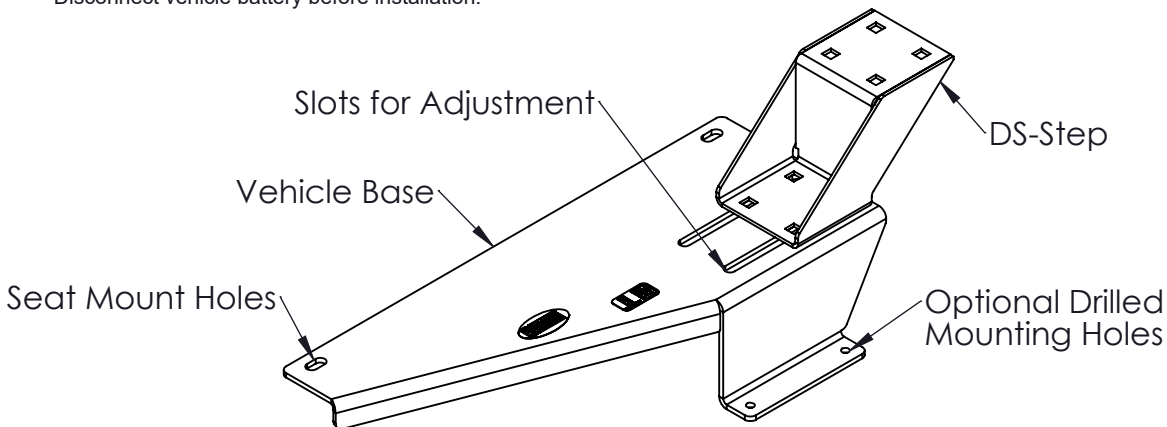

## **To Install:**

1. Attach the DS-Step to the vehicle base with the 3/8-16 carriage bolts, lock washers, washers, and nuts provided. Installing the carriage bolts facing up will allow for adjustment once in the vehicle. If a cleaner looking install is desired with the carriage bolts down, first mock up the base and DS-Step positioning inside the vehicle before tightening the nuts and fixing the DS-step in position.
2. Remove the two front passenger seat bolts using a T50 bit.
3. Place the vehicle base between the floor and passenger seat rails. Reinstall the passenger seat bolts and tighten.
4. If the nuts were installed on the top side in Step 1, adjust the position of the DS-Step and tighten the nuts to fix it in position on the base.

**Optional** - If desired, extra screws can be drilled into the vehicle floor using the optional drilled mounting holes on the foot. Verify the area beneath the foot is clear of any obstructions before drilling.

### **Product Mounting Disclaimer**

Gamber-Johnson is not liable under any theory of contract or tort law for any loss, damage, personal injury, special, incidental or consequential damages for personal injury or other damage of any nature arising directly or indirectly as a result of the improper installation or use of its products in vehicle or any other application. In order to safely install and use Gamber-Johnson products full consideration of vehicle occupants, vehicle systems (i.e., the location of fuel lines, brakes lines, electrical, drive train or other systems), air-bags and other safety equipment is required. Gamber-Johnson specifically disclaims any responsibility for the improper use or installation of its products not consistent with the original vehicle manufactures specifications and recommendations, Gamber-Johnson product instruction sheets, or workmanship standards as endorsed through the Gamber-Johnson Certified Installer Program.

© Copyright 2018 Gamber-Johnson, LLC

If you need assistance or have questions, call Gamber-Johnson at 1-800-456-6868

## Support Bracket Install:

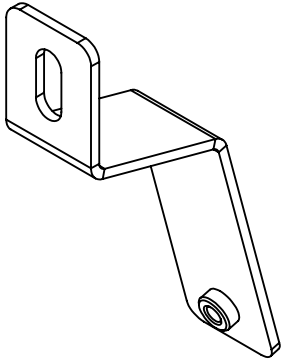

CHEVY TAHOE 2021+  
GJ PN: 7160-1602

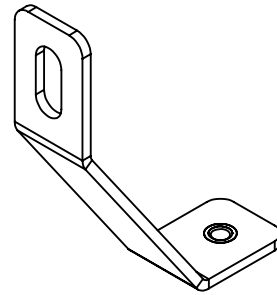

CHEVY SILVERADO/SIERRA 2019+, HD 2020+  
GJ PN: 7160-1608

Install -

\*Installation steps are the same for both vehicles, verify the correct bracket is with the correct vehicle

1. To remove lower center trim, on driver side remove bolt with a 7mm socket.



Fig. 1

2. With driver side bolt removed, lower trim can be pulled forward and removed



Fig. 2

3. With trim removed, on passenger side remove OEM bolt with a 13MM socket and install bracket in place with OEM bolt. Then reinstall the lower trim back in place with 7MM bolt on driver side.



Fig. 3



Fig. 4