



# INSTALLATION INSTRUCTIONS

## Product

7160-2034

X10DR Wireless Microphone Bracket

## Revision

Rev A

## Form

INST-1218

Printing Spec: PS-001

1. Attach the rectangular X10DR Wireless mic adapter bracket (supplied with the microphone cradle) to the mounting bracket with the (4) #6-32 x 1/4" long machine screws found in hardware bag 7120-1236.
2. Attach the wireless mic cradle to the adapter bracket with the screw supplied with the cradle.
3. Loosely attach the 1/4" x 1" carriage bolt, flat washer, lock washer, and hex nut to the mounting bracket as shown below.
4. Insert the carriage bolt head through one of the keyhole slots on the top plate and slide into the desired location. Tighten the hex nut to hold it in place.

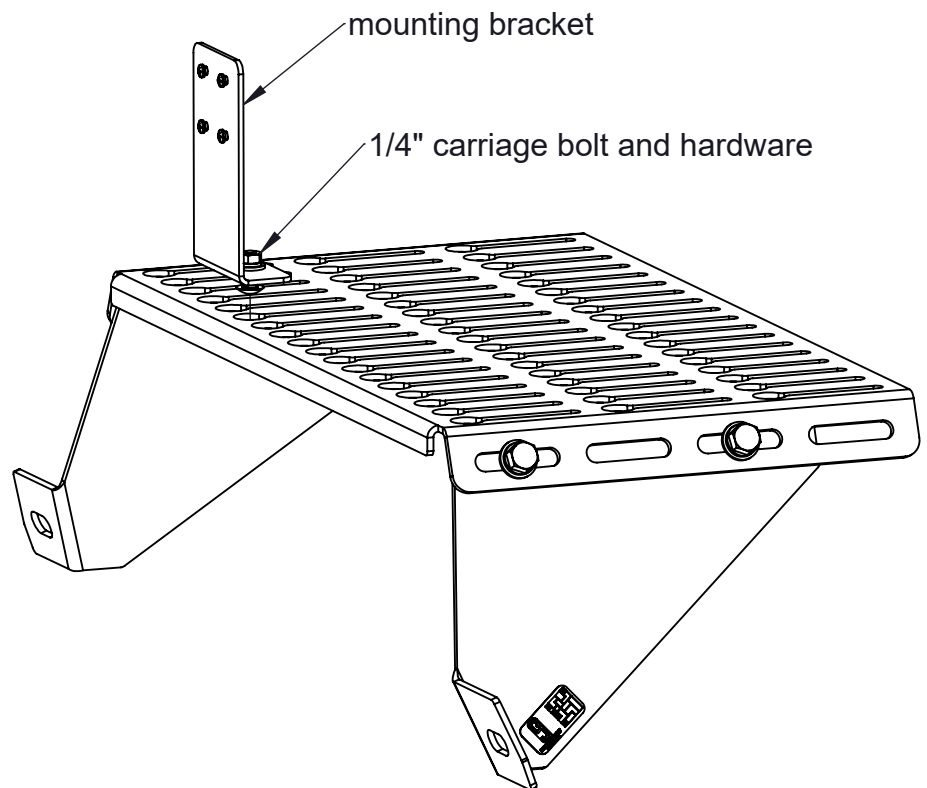

### Product Mounting Disclaimer

Gamber-Johnson is not liable under any theory of contract or tort law for any loss, damage, personal injury, special, incidental or consequential damages for personal injury or other damage of any nature arising directly or indirectly as a result of the improper installation or use of its products in vehicle or any other application. In order to safely install and use Gamber-Johnson products full consideration of vehicle occupants, vehicle systems (i.e., the location of fuel lines, brake lines, electrical, drive train or other systems), air-bags and other safety equipment is required. Gamber-Johnson specifically disclaims any responsibility for the improper use or installation of its products not consistent with original vehicle manufactures specifications and recommendations, Gamber-Johnson product instruction sheets, or workmanship standards as endorsed through the Gamber-Johnson Certified Installer Program.

© Copyright 2024 Gamber-Johnson, LLC

If you need assistance or have questions, call Gamber-Johnson at 1-800-456-6868

