



INSTALLATION INSTRUCTIONS

Product

7160-1505

FIXED BASE, CLAMSHELL WITH ARTICULATING ARM & LARGE PLATE

Revision

Rev A

Form

INST-966

Printing Spec: PS-001

This instruction sheet is for the fixed base clamshell with articulating arm and large plate (7160-1505). It is designed to clamp onto rectangular tubing and hold a computer cradle or docking station on a lift vehicle.

Attaching the mount:

1. Attach the mount to the rectangular tube by clamping the fixed base to the tube with the back plate and 3/8" dia. carriage bolts supplied in hardware bag 7120-0555.
2. Position the mount so the fixed base is level with the ground. This prevents gravity from affecting the mount if the articulating arm is not tightened down completely.
3. Once in the desired position, tighten the 3/8" dia. carriage bolts to hold the mount in place. Make sure to position the carriage bolts as close to the rectangular tube as possible to best secure the mount in place.
4. A computer mount can now be attached to the clevis and positioned as desired.

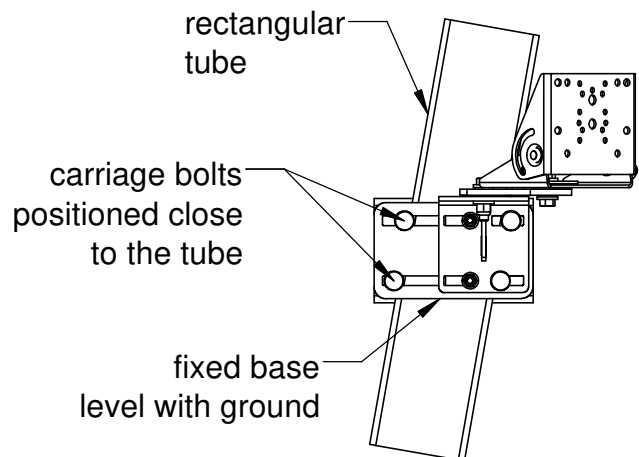
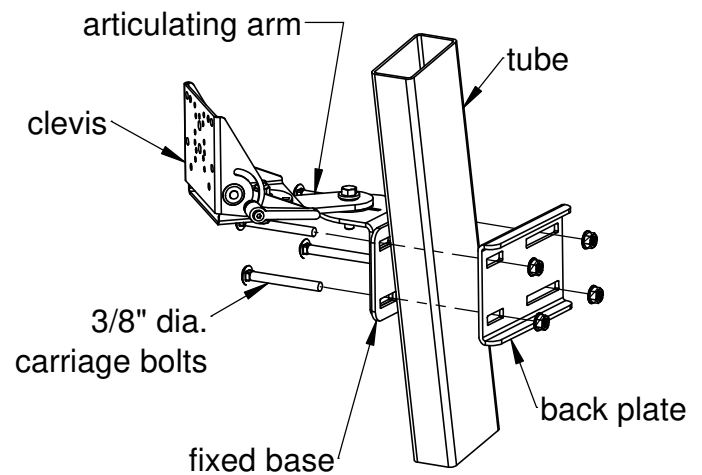

Product Mounting Disclaimer

Gamber-Johnson is not liable under any theory of contract or tort law for any loss, damage, personal injury, special, incidental or consequential damages for personal injury or other damage of any nature arising directly or indirectly as a result of the improper installation or use of its products in vehicle or any other application. In order to safely install and use Gamber-Johnson products full consideration of vehicle occupants, vehicle systems (i.e., the location of fuel lines, brake lines, electrical, drive train or other systems), air-bags and other safety equipment is required. Gamber-Johnson specifically disclaims any responsibility for the improper use or installation of its products not consistent with original vehicle manufactures specifications and recommendations, Gamber-Johnson product instruction sheets, or workmanship standards as endorsed through the Gamber-Johnson Certified Installer Program.

© Copyright 2019 Gamber-Johnson, LLC

If you need assistance or have questions, call Gamber-Johnson at 1-800-456-6868