



INSTALLATION INSTRUCTIONS

<u>Product</u> Zirkona Mounting System	<u>Revision</u> Rev K	<u>Form</u> INST-494
Printing Spec: PS-001		

These general instructions are intended to cover most of the components of the Zirkona product line.

⚠Warning!

-Always apply thread locker on all M20 threads of the Zirkona product line. Loctite EA 9460, EA 9461 or EA 9466 EPOXY is the recommended thread locker for all these threaded joints.

-Do not exceed maximum payload weight. See charts below:

	<u>Dynamic load</u>	<u>Static load</u>
Small Joiners(7110-1234, -1237, -1239)	3 lbs. (1.4kg)	22 lbs. (10kg)
Medium Joiners(7110-1235, -1222, -1259, -1406, -1407)	6 lbs. (2.8kg)	33 lbs. (15kg)
Large Joiners(7110-1236, -1260)	11 lbs. (5kg)	55 lbs. (25kg)
Large Short Joiner(7110-1416)	30 lbs. (13.6kg)	145 lbs. (65.7kg)

*Extension tubes will lower the overall payload rating of the mount. The longer the extension, the lower the maximum payload of the mount. As a general rule, lower the maximum payload 20% for every 50mm of extension (Ex: 100mm extension = reduces the payload by 40%)

-The suction cup bases require a smooth flat surface to affix to. Both the surface and the rubber of the base should be cleaned with water and/or a mild cleaner. Press the base hard against the surface and pull down the locking lever. Repeat this procedure at least once a month.

Pat.: www.gamberjohnson.com/patents <<http://www.gamberjohnson.com/patents>>

Product Mounting Disclaimer

Gamber-Johnson is not liable under any theory of contract or tort law for any loss, damage, personal injury, special, incidental or consequential damages for personal injury or other damage of any nature arising directly or indirectly as a result of the improper installation or use of its products in vehicle or any other application. In order to safely install and use Gamber-Johnson products full consideration of vehicle occupants, vehicle systems (i.e., the location of fuel lines, brakes lines, electrical, drive train or other systems), air-bags and other safety equipment is required. Gamber-Johnson specifically disclaims any responsibility for the improper use or installation of its products not consistent with the original vehicle manufactures specifications and recommendations, Gamber-Johnson product instruction sheets, or workmanship standards as endorsed through the Gamber-Johnson Certified Installer Program.

© Copyright 2017 Gamber-Johnson, LLC

If you need assistance or have questions, call Gamber-Johnson at 1-800-456-6868
gamberjohnson.com\zirkona
5001 Joerns Drive, Stevens Point, WI 54481, USA

Use of the Zirkona product line.

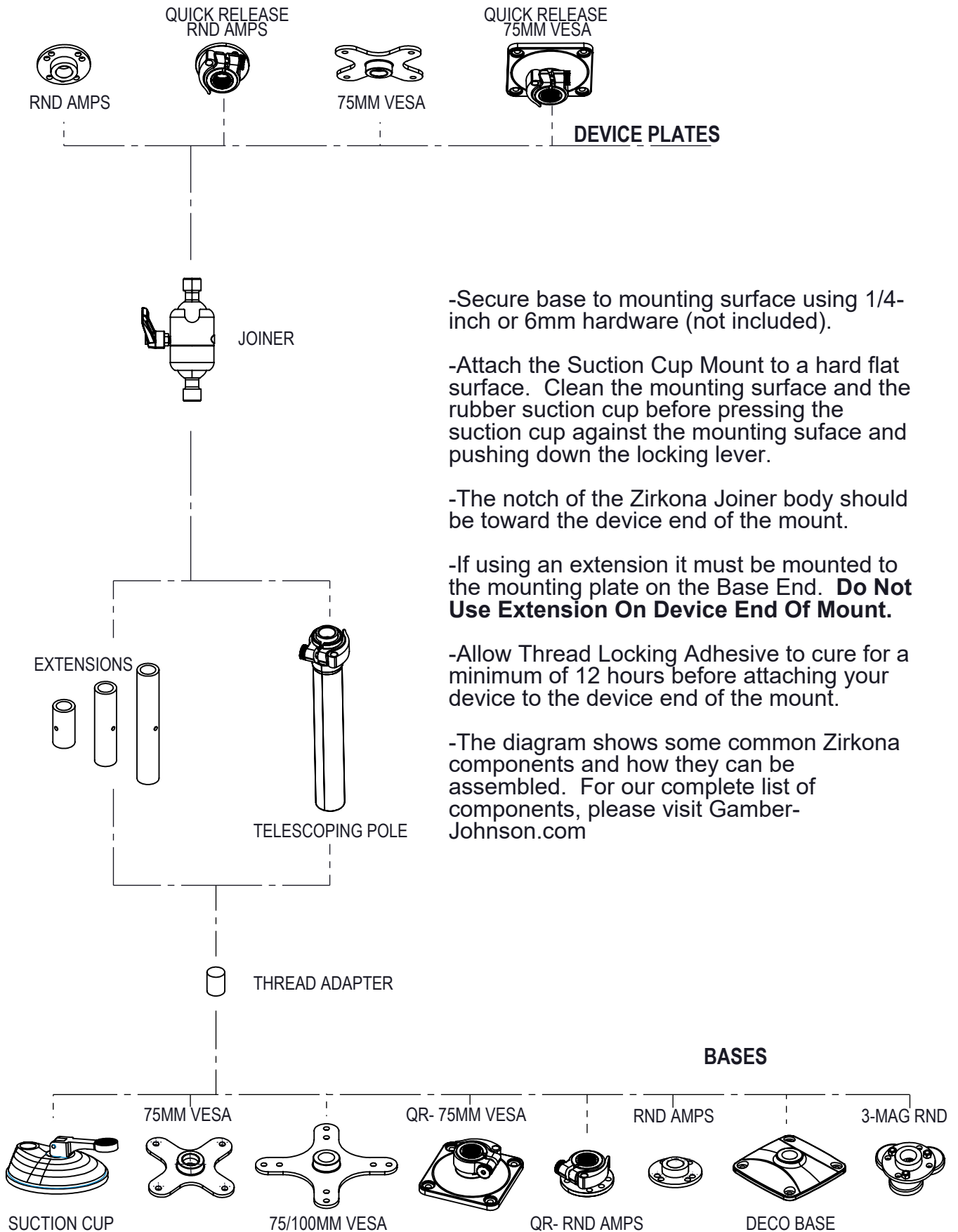

-Secure base to mounting surface using 1/4-inch or 6mm hardware (not included).

-Attach the Suction Cup Mount to a hard flat surface. Clean the mounting surface and the rubber suction cup before pressing the suction cup against the mounting surface and pushing down the locking lever.

-The notch of the Zirkona Joiner body should be toward the device end of the mount.

-If using an extension it must be mounted to the mounting plate on the Base End. **Do Not Use Extension On Device End Of Mount.**

-Allow Thread Locking Adhesive to cure for a minimum of 12 hours before attaching your device to the device end of the mount.

-The diagram shows some common Zirkona components and how they can be assembled. For our complete list of components, please visit Gamber-Johnson.com

SPANNER WRENCH
(p/n 19511)

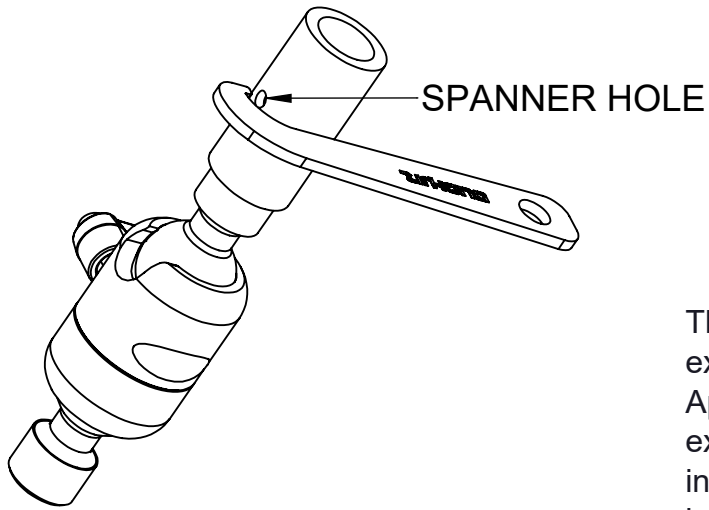

The spanner wrench is used to tighten extension tubes onto the joiner bodies. Apply epoxy thread locker EA 9460 on external and internal M20 threads, then insert the hook end of the spanner wrench into the hole of the extension tube to tighten the joint.