



INSTALLATION INSTRUCTIONS

<u>Product</u>	<u>Revision</u>	<u>Form</u>
7160-2103, 7160-2122, 7160-2239, 7160-2240	Rev B	INST-1258
2" TO 3" ROUND POLE MOUNT		Printing Spec: PS-001

This instruction sheet is for installing a guard leg mount on a round guard leg of a forklift. The mount is designed to attach to the inside surface of a forklift overhead guard leg up to 3" dia. The mount has a clevis attached to an arm which allows the user to position the device (docking station or VMU) in a location that best fits their specific application.

Attaching the mount to the round overhead guard leg:

1. Insert the 3/8 carriage bolts through the back plate on the outside of the vehicle and through the interior main bracket as shown. Make sure the main bracket and the arm are level with the floor and attach the 3/8" flange nuts on the inside of the bracket to tighten the mount to the round pole.

3. Attach the device (docking station or VMU) to the clevis with the hardware supplied with the device.

Note: There are 2 mounting hole locations on each side of the main bracket. The end user can remove the 3/8 hex bolt that holds the arm in the current location and move it to the secondary location. This will change where the arm pivots.

Attaching the mount to the left front overhead guard leg:

To mount on the left side of the vehicle, flop over the mount 180 deg. and attach to the left side guard leg. Remove the arms and flip them over so the clevises are in the upward position, then reattach.

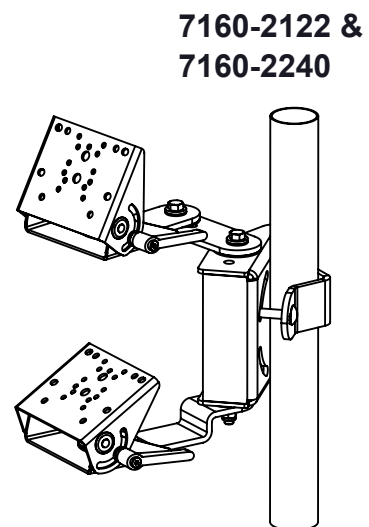
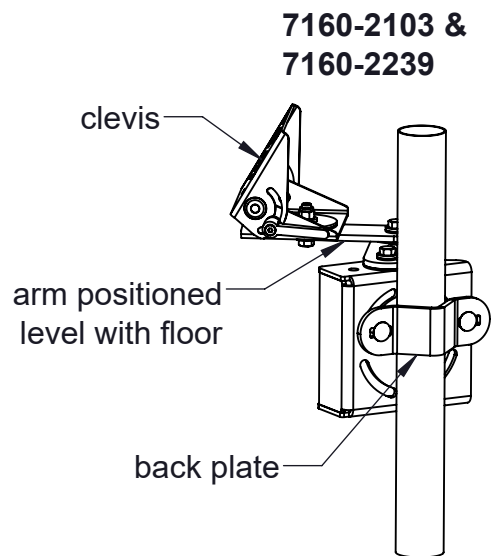

Product Mounting Disclaimer

Gamber-Johnson is not liable under any theory of contract or tort law for any loss, damage, personal injury, special, incidental or consequential damages for personal injury or other damage of any nature arising directly or indirectly as a result of the improper installation or use of its products in vehicle or any other application. In order to safely install and use Gamber-Johnson products full consideration of vehicle occupants, vehicle systems (i.e., the location of fuel lines, brake lines, electrical, drive train or other systems), air-bags and other safety equipment is required. Gamber-Johnson specifically disclaims any responsibility for the improper use or installation of its products not consistent with original vehicle manufacturers specifications and recommendations, Gamber-Johnson product instruction sheets, or workmanship standards as endorsed through the Gamber-Johnson Certified Installer Program.

© Copyright 2025 Gamber-Johnson, LLC

If you need assistance or have questions, call Gamber-Johnson at 1-800-456-6868



INSTALLATION INSTRUCTIONS

Product

7160-1995, 7160-2020, 7160-2239, 7160-2240

GUARD LEG MOUNT

Revision

Rev B

Form

INST-1197

Printing Spec: PS-001

This instruction sheet is for installing a guard leg mount on the front overhead guard leg of a forklift. The mount is designed to attach to the inside surface of a forklift overhead guard leg. The mount has a clevis attached to an arm which allows the user to position the device (docking station or VMU) in a location that best fits their specific application.

Attaching the mount to the right front overhead guard leg:

1. Use the appropriate carriage bolts (typically the 3.50" long) provided in the hardware bag to attach the mount to the guard leg. Insert the 3/8 carriage bolts through the diamond shaped back plate on the outside of the vehicle and through the interior main bracket as shown. Attach the 3/8" flange nuts on the inside of the bracket.
2. With the mounting bracket and arm positioned level with the floor, rotate the carriage bolts in the curved slots until they are tight against the overhead guard leg and tighten in place.
3. Attach the device (docking station or VMU) to the clevis with the hardware supplied with the device.

Note: There are 2 mounting hole locations on each side of the main bracket. The end user can remove the 3/8 hex bolt that holds the arm in the current location and move it to the secondary location. This will change the location where the arm pivots.

Attaching the mount to the left front overhead guard leg:

To mount on the left side of a vehicle, flip over the mount 180 deg. and attach to the left side guard leg. Remove the arms and flip them over so the clevises are in the upward position, then reattach.

7160-1995 & 7160-2239

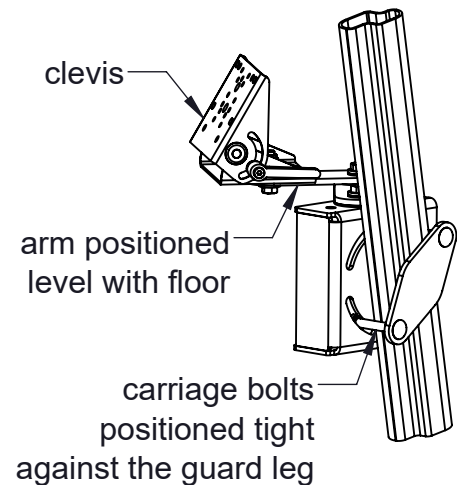

7160-2020 & 7160-2240

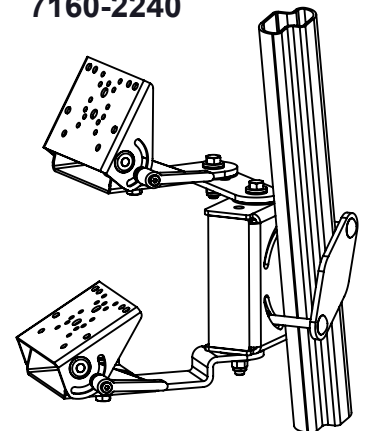

Product Mounting Disclaimer

Gamber-Johnson is not liable under any theory of contract or tort law for any loss, damage, personal injury, special, incidental or consequential damages for personal injury or other damage of any nature arising directly or indirectly as a result of the improper installation or use of its products in vehicle or any other application. In order to safely install and use Gamber-Johnson products full consideration of vehicle occupants, vehicle systems (i.e., the location of fuel lines, brake lines, electrical, drive train or other systems), air-bags and other safety equipment is required. Gamber-Johnson specifically disclaims any responsibility for the improper use or installation of its products not consistent with original vehicle manufactures specifications and recommendations, Gamber-Johnson product instruction sheets, or workmanship standards as endorsed through the Gamber-Johnson Certified Installer Program.

© Copyright 2025 Gamber-Johnson, LLC

If you need assistance or have questions, call Gamber-Johnson at 1-800-456-6868