



INSTALLATION INSTRUCTIONS

Product**7160-1625****SAMSUNG XCOVER 5 CHARGING CRADLE****Revision****B****Form****INST-1040****Printing Spec: PS-001**

This instruction sheet is for the following products:

Item No.**7160-1625-10, (-S)**

Attached Power Cable with Bare Wire End

7160-1625-20

Attached Power Cable with Cig Adapter End

7160-1625-90, (-S)

Cradle with No Electronics

This instruction sheet is for the Samsung XCover 5 Charging Cradle only. For instructions on features, set-up, and operation of the phone, please refer to the manual provided by Samsung with the phone.

This cradle is designed to be used with a variety of Gamber-Johnson mounting systems. Installation instructions for other Gamber-Johnson products are provided with each individual product.

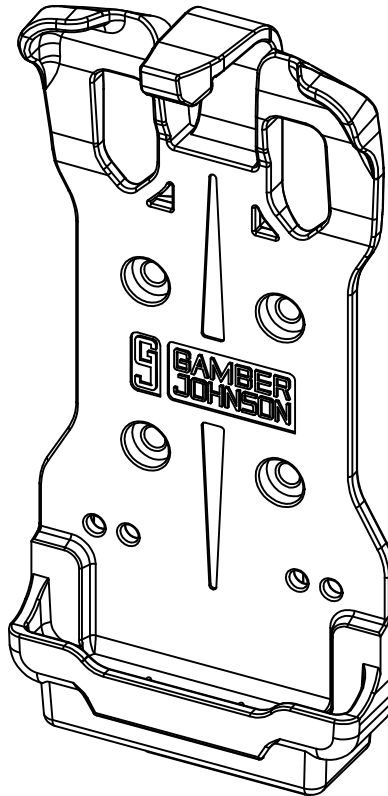
**Product Mounting Disclaimer**

Gamber-Johnson is not liable under any theory of contract or tort law for any loss, damage, personal injury, special, incidental or consequential damages for personal injury or other damage of any nature arising directly or indirectly as a result of the improper installation or use of its products in vehicle or any other application. In order to safely install and use Gamber-Johnson products full consideration of vehicle occupants, vehicle systems (i.e., the location of fuel lines, brakes lines, electrical, drive train or other systems), air-bags and other safety equipment is required. Gamber-Johnson specifically disclaims any responsibility for the improper use or installation of its products not consistent with the original vehicle manufactures specifications and recommendations, Gamber-Johnson product instruction sheets, or workmanship standards as endorsed through the Gamber-Johnson Certified Installer Program.

PRE-INSTALLATION RECOMMENDATIONS

Conduct a "Bench Test"

Gamber-Johnson strongly advises a "bench test" be conducted to verify all electronic and software issues are resolved prior to installation:

1. Make sure the phone is operational by itself.
2. Insert phone into the docking station and verify that the phone is operating in the dock and the battery is charging.

Gamber-Johnson recommends positioning of all mounts and equipment in the vehicle prior to the actual install to verify that mounting locations are safe and practical.

IMPORTANT SAFETY INFORMATION FOR INSTALLERS

Safety is dependent on the proper installation and servicing of this docking station. It is important to read and follow all instructions before installing this product.

To properly install a Gamber-Johnson docking station you must have a good understanding of automotive electrical procedures and systems, along with proficiency in the installation and service of aftermarket vehicle equipment.

There are no adjustments required at any time of the electrical components within the docking station. **Opening the docking station will void the product warranty.**

During Installation:

DO NOT connect this docking station to the vehicle battery until:

1. All other electrical connections are made
2. Mounting of all components is complete
3. Verification that no shorts exist in the entire system

DO NOT install equipment or route wiring or cords in the deployment path of any air bag.

When drilling into the vehicle, DO make sure that both sides of the surface are clear of anything that could be damaged.

CAUTION: *If wiring is shorted to the frame, high current conductors can cause hazardous sparks resulting in electrical fires or flying molten metal.*

After installation:

Test the docking station to ensure that it is working properly.

File these instructions in a safe place and refer to them when performing maintenance or re-installing.

WARNING: *Failure to follow all safety precautions and instructions may result in property damage, serious injury, or death.*

FEATURE IDENTIFICATION

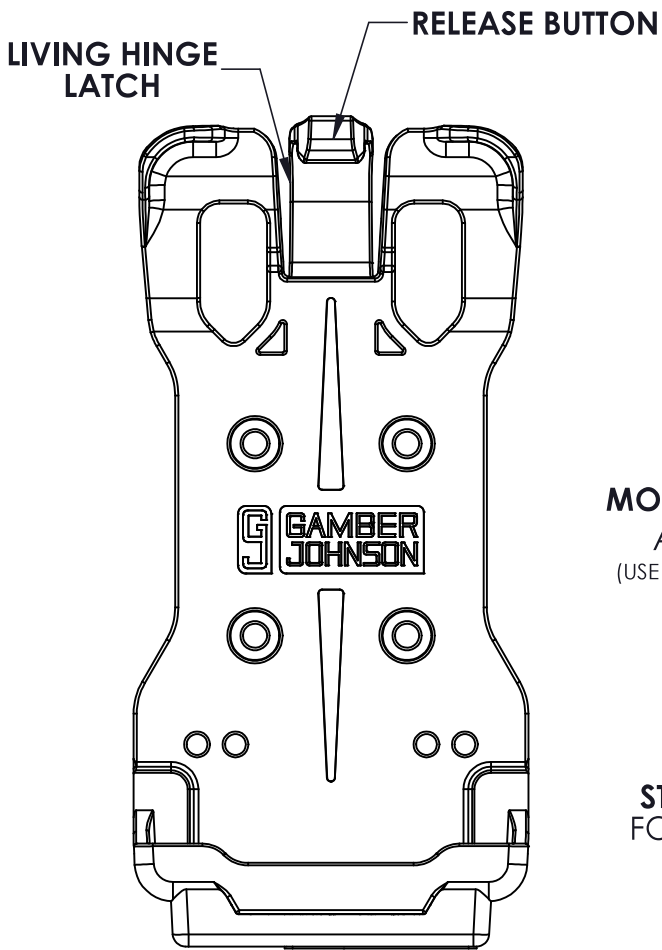
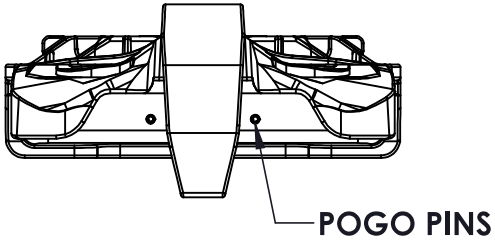

MOUNTING PATTERN
AMPS PATTERN
(USE PROVIDED HARDWARE)

STRAIN RELIEF
FOR CABLE TIES

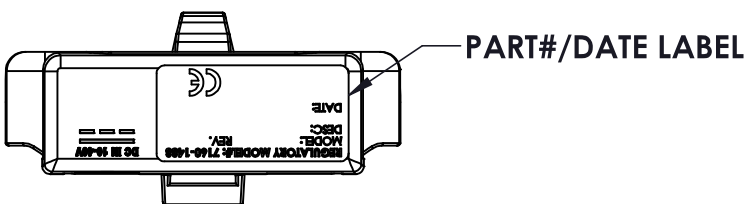
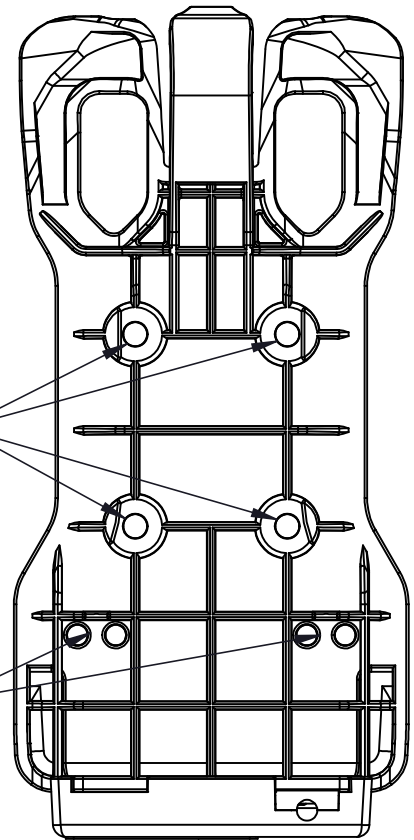

CABLE MANAGEMENT

1.) Connect the bare wire or cigarette plug end of the power cable to the power source. Press the cable into the strain relief slot on the back of the cradle, leaving a loop to avoid stressing the cable.

2.) Use a zip tie (provided) to secure the cable.



INSERTING AND REMOVING PHONE

1.) Insert the bottom of the phone into the cavity of the cradle.

2.) Rotate the top of the phone and press until the latch snaps over the front of the phone.



1.) Press up on the release button until the latch clears the top of the phone.

2.) Rotate the phone forward and pull the phone up and away from the cradle.



Regulatory Certification Information

Regulatory Model #: 7160-1625

GJ Model #'s: 7160-1625-10, (-S)
7160-1625-20
7160-1625-90, (-S)

Descriptions:

-10: CRADLE-SAMSUNG-XCOVER 5 POWERED, BARE WIRE LEADS
-20: CRADLE-SAMSUNG-XCOVER 5 POWERED, CIG ADAPTER
-90: CRADLE-SAMSUNG-XCOVER 5 NO ELECTRONICS

Certifications:

- EN55032:2015/AC:2016, Class B
- VCCI-CISPR 32: 2015
- AS/NZS CISPR 32:2015
- FCC 47 CFR Part 15 Subpart B: Class B
- ICES-003 Issue 7: Class B
- EN50498:2010

This device complies with Part 15 of the FCC Rules. Operation is subject to the following two conditions. (1) this device may not cause harmful interference, and (2) this device must accept any interference received, including interference that may cause undesired operation.



Gamber-Johnson LLC, 5001 Joerns Dr.,
Stevens Point, WI, 54481, USA, 715-344-3482



INSTALLATION INSTRUCTIONS

<u>Product</u> Zirkona Mounting System	<u>Revision</u> Rev K	<u>Form</u> INST-494
Printing Spec: PS-001		

These general instructions are intended to cover most of the components of the Zirkona product line.

⚠Warning!

-Always apply thread locker on all M20 threads of the Zirkona product line. Loctite EA 9460, EA 9461 or EA 9466 EPOXY is the recommended thread locker for all these threaded joints.

-Do not exceed maximum payload weight. See charts below:

	<u>Dynamic load</u>	<u>Static load</u>
Small Joiners(7110-1234, -1237, -1239)	3 lbs. (1.4kg)	22 lbs. (10kg)
Medium Joiners(7110-1235, -1222, -1259, -1406, -1407)	6 lbs. (2.8kg)	33 lbs. (15kg)
Large Joiners(7110-1236, -1260)	11 lbs. (5kg)	55 lbs. (25kg)
Large Short Joiner(7110-1416)	30 lbs. (13.6kg)	145 lbs. (65.7kg)

*Extension tubes will lower the overall payload rating of the mount. The longer the extension, the lower the maximum payload of the mount. As a general rule, lower the maximum payload 20% for every 50mm of extension (Ex: 100mm extension = reduces the payload by 40%)

-The suction cup bases require a smooth flat surface to affix to. Both the surface and the rubber of the base should be cleaned with water and/or a mild cleaner. Press the base hard against the surface and pull down the locking lever. Repeat this procedure at least once a month.

Pat.: www.gamberjohnson.com/patents <<http://www.gamberjohnson.com/patents>>

Product Mounting Disclaimer

Gamber-Johnson is not liable under any theory of contract or tort law for any loss, damage, personal injury, special, incidental or consequential damages for personal injury or other damage of any nature arising directly or indirectly as a result of the improper installation or use of its products in vehicle or any other application. In order to safely install and use Gamber-Johnson products full consideration of vehicle occupants, vehicle systems (i.e., the location of fuel lines, brakes lines, electrical, drive train or other systems), air-bags and other safety equipment is required. Gamber-Johnson specifically disclaims any responsibility for the improper use or installation of its products not consistent with the original vehicle manufactures specifications and recommendations, Gamber-Johnson product instruction sheets, or workmanship standards as endorsed through the Gamber-Johnson Certified Installer Program.

© Copyright 2017 Gamber-Johnson, LLC

If you need assistance or have questions, call Gamber-Johnson at 1-800-456-6868
gamberjohnson.com\zirkona
5001 Joerns Drive, Stevens Point, WI 54481, USA

Use of the Zirkona product line.

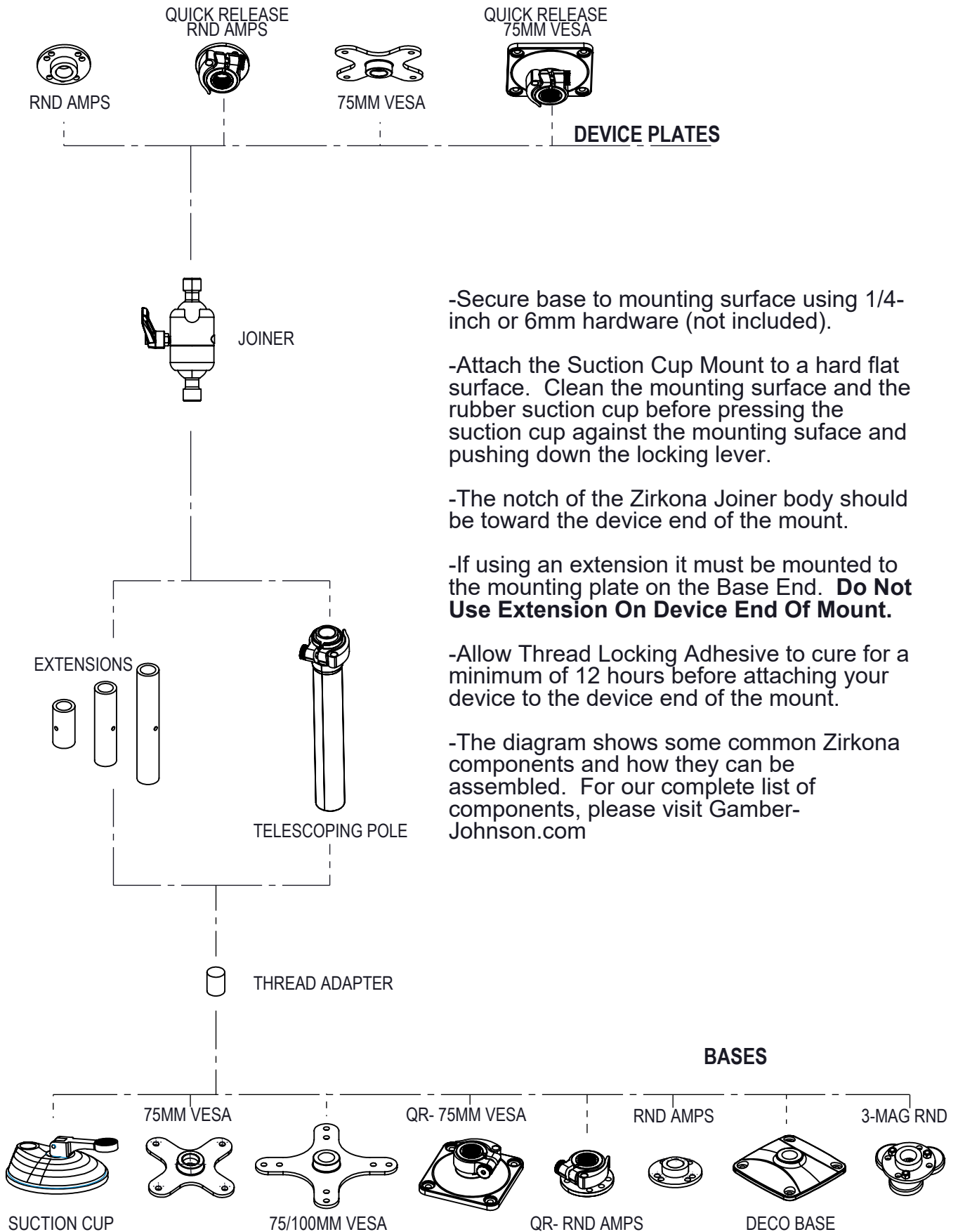

SPANNER WRENCH
(p/n 19511)

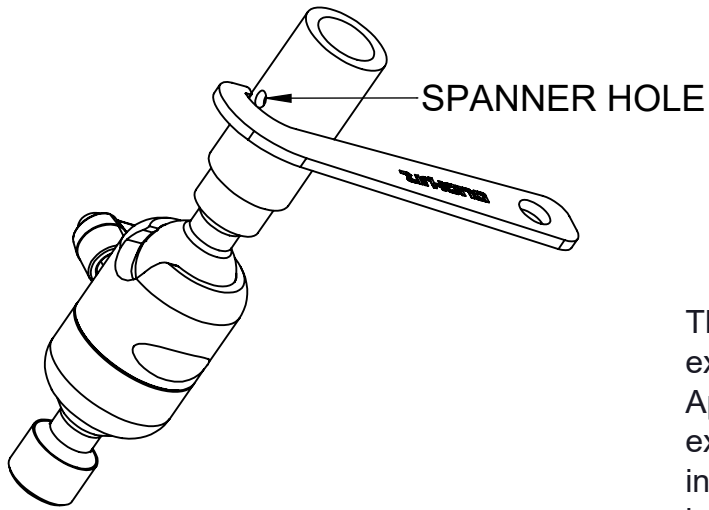

The spanner wrench is used to tighten extension tubes onto the joiner bodies. Apply epoxy thread locker EA 9460 on external and internal M20 threads, then insert the hook end of the spanner wrench into the hole of the extension tube to tighten the joint.