



Docking Station For Getac B360 Laptop Computers

User Guide

Description	Part Number
DOCKING STATION FOR GETAC B360 LAPTOP NPT	AS7.G360.100-GJ
DOCKING STATION FOR GETAC B360 LAPTOP NPT WITH POWER ADAPTER	AS7.G360.100-PS-GJ
DOCKING STATION FOR GETAC B360 LAPTOP TPT	AS7.G360.102-GJ
DOCKING STATION FOR GETAC B360 LAPTOP TPT WITH POWER ADAPTER	AS7.G360.102-PS-GJ
CRADLE FOR GETAC B360 LAPTOP NPT	AS7.G360.103-GJ
CRADLE FOR GETAC B360 LAPTOP NPT WITH POWER ADAPTER	AS7.G360.103-PS-GJ
CRADLE FOR GETAC B360 LAPTOP TPT	AS7.G360.105-GJ
CRADLE FOR GETAC B360 LAPTOP TPT WITH POWER ADAPTER	AS7.G360.105-PS-GJ

www.gamberjohnson.com

call us at 1-800-456-6868 | ©2020 Gamber-Johnson LLC.

General Instructions

SAFETY:

- Safety is dependent on the proper installation and servicing of this docking station. It is important to read and follow all instructions before installing this product.
- Proper installation requires a good understanding of automotive electrical systems and is recommended to be performed by qualified technicians only.
- There are no adjustments or user serviceable parts within the docking station. Opening the docking station will void the product warranty
- Do not install equipment or route wires in the deployment path of any air bag, or where it may interfere with critical safety or operating controls of any vehicle.

POWER:

- The power maximum input should be 19 VDC/6.32A. Use a recommended power supply for the dock.

WIRING:

- Gamber-Johnson does not recommend relying on a cigarette socket adaptor for powering vehicle docks. We recommend hard wiring the power adapter using a good clean ground direct from the vehicle battery neg(-) post, and pos(+) supply from a fused 12vdc location also directly from the vehicle battery. All peripherals connecting to the docking station requiring external power should get power and ground from the same location as the dock.
- Visit www.gamberjohnson.com for a copy of our general wiring and troubleshooting guide.

Proper Use and Care:

- Proper care and use of this product is critical to maximize safety and to prevent damage to the docking station and laptop.
- Do not store, place or drag any object on top of the docking station.
- Visually inspect the docking station and laptop for any defect before using the dock or docking the laptop. Do not use if damaged.
- Do not attempt to dock a computer or dock with wet contacts

Environmental:

- Storage: -40°C to 85°C (-40°F to 185°F)
- Operating: -21°C to 50°C (-5.8°F to 122°F)

SERVICING [ENTRETIEN]:

- If the dock does not work as intended, please contact Gamber-Johnson for troubleshooting or to schedule a service. *[Si le dock ne fonctionne pas comme prévu, contactez Gamber-Johnson pour le dépannage ou pour planifier un service.]*
- Servicing of the dock should be only done by authorized service center personnel. Unauthorized servicing of the dock will void its warranty. *[L'entretien du dock ne doit être effectué que par le personnel du centre de service autorisé. Un entretien non autorisé du dock annulera sa garantie.]*

Product Mounting Disclaimer

Gamber-Johnson is not liable under any theory of contract or tort law for any loss, damage, personal injury, special, incidental or consequential damages for personal injury or other damage of any nature arising directly or indirectly as a result of the improper installation or use of its products in vehicle or any other application. In order to safely install and use Gamber-Johnson products full consideration of vehicle occupants, vehicle systems (i.e., the location of fuel lines, brake lines, electrical, drive train or other systems), air-bags and other safety equipment is required. Gamber-Johnson specifically disclaims any responsibility for the improper use or installation of its products not consistent with original vehicle manufactures specifications and recommendations, Gamber-Johnson product instruction sheets, or workmanship standards as endorsed through the Gamber-Johnson Certified Installer Program.

DESCRIPTION OF PARTS AND LAYOUT

Note: All pictures used in this guide are of Tri Pass Thru (TPT) docking station model (Part # AS7.G360.102-GJ). However, processes and information relate to other variants of the same dock mentioned in previous page.

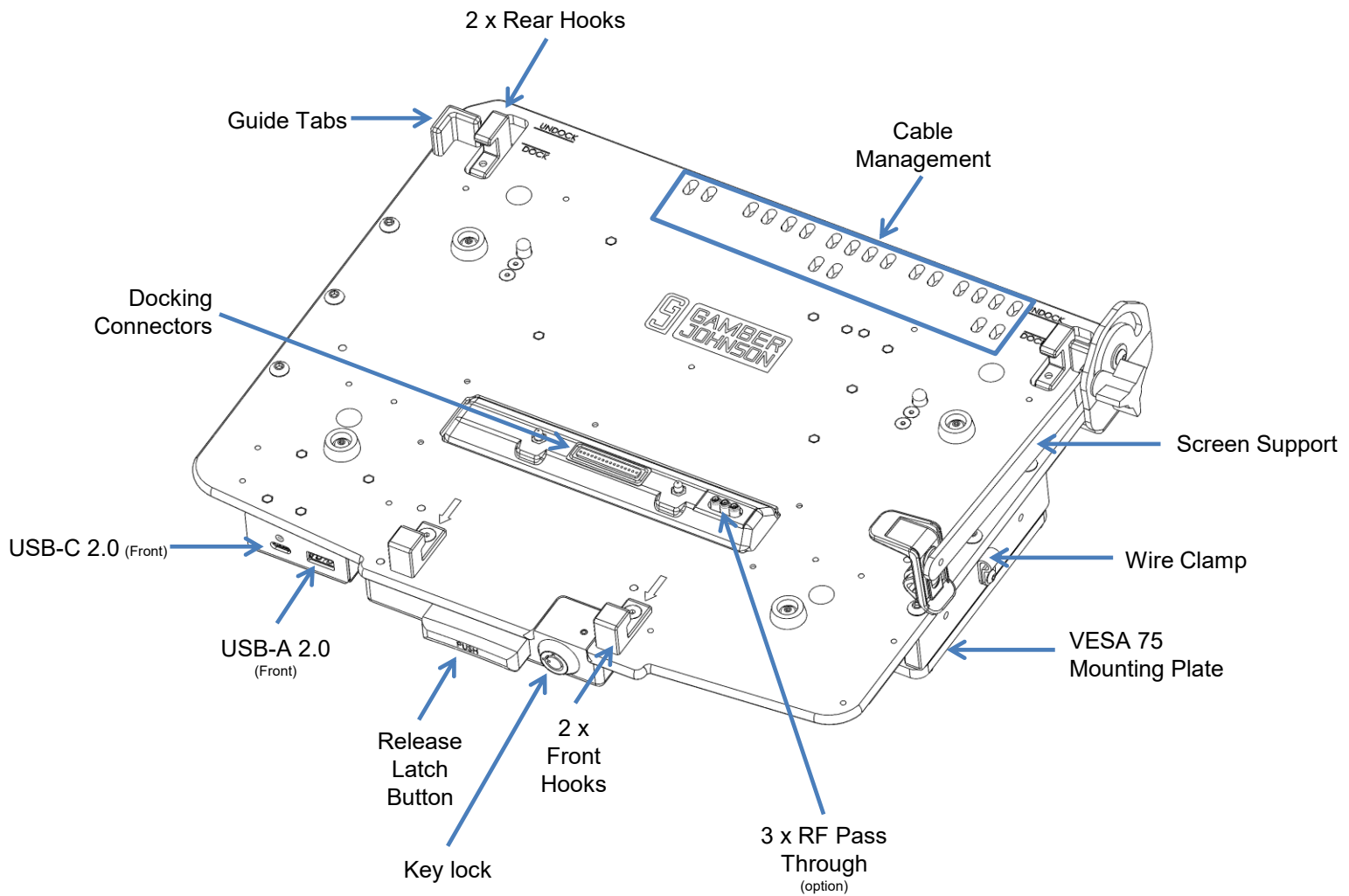

DESCRIPTION OF PARTS AND LAYOUT

REAR PORT VIEW

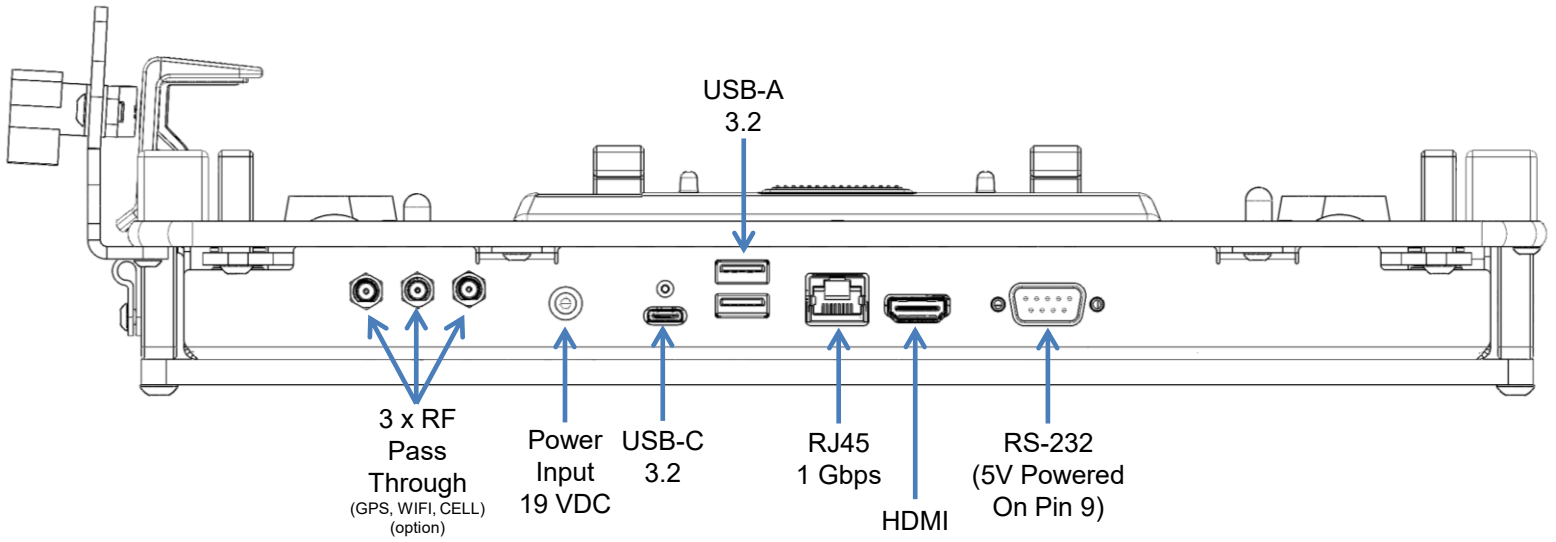

Docking the Laptop

Step 1

Ensure that the dock is unlocked and unlatched. If locked, insert key and rotate lock 90 degrees counter-clockwise. If latched, push the front release latch such that the back hooks move all the way out. An audible noise will be heard once fully unlatched.

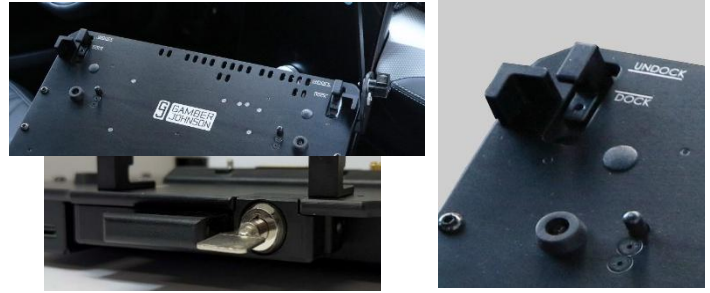

Step 2

Loosen the side knob and rotate the screen support to the back to prevent blocking the laptop during docking.

Lead the front of the laptop into the front hooks on the dock such that the pockets on the laptop align with the front hooks. The guide tabs should help align the laptop as well. Carefully position the laptop to ensure proper alignment and to prevent damage.

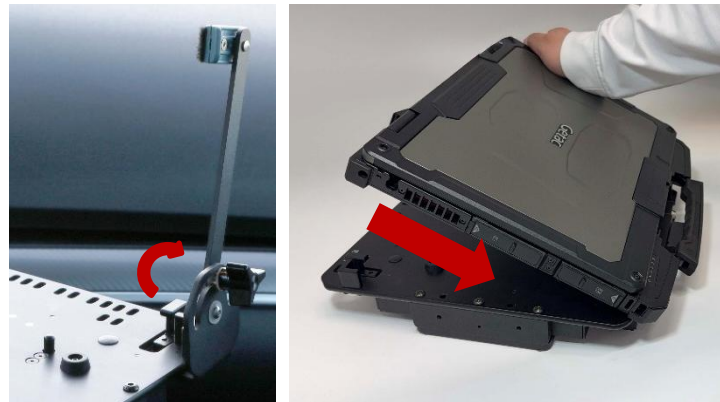

Step 3

Push gently in the back center of the laptop so that rear hook latches. If any resistance is felt, remove the laptop and re-align. A click sound should be heard when the rear hook latches. Verify the laptop is fully docked by lifting the laptop lightly. If properly docked the laptop will remain in place.

*The laptop can be docked into the dock with lid open or close. If the lid is open, make sure that no keys are pressed while docking



Step 4

Position the screen to the desired location. Rotate and slightly pull the screen support arm until the tab rests against the side of the laptop screen. Adjust the screen support tension using the adjustment knob as needed.



Step 5

For additional security and theft deterrence, insert and rotate key 90 degrees clockwise and remove the key to lock the laptop in the docking station. The laptop is only fully secure once the key is removed.



Undocking the Laptop

Step 1

Ensure that the dock is unlocked. If locked, insert key and rotate lock 90 degrees counter-clockwise.



Step 2

Rotate the screen support to the back to prevent blocking the laptop during removal.

Use your thumb to push in the front release button on the front of the dock. This will push the rear clamps out and the laptop will eject with a small click sound.



Step 3

Once the laptop ejects, gently lift the laptop out of the dock. Take care not to drag the laptop or any other device across the top surface of the dock to prevent damage to the pins.



Cable Management & Mounting

Connect all cables securely to dock connections and use tie straps to secure cables to the cable management bracket. Ensure to leave enough slack in wires exiting the dock so that any positioning adjustments will not strain the cables or connections during use.

Use tie straps to secure opposite cable ends to another suitable location in the vehicle.



The standard mounting bracket that comes with the vehicle dock features an industry standard VESA 75. This allows easy mounting to many pre-existing mounts as well as dedicated mounts from PMT. Multiple hole patterns are also present for ease of installation with various other infrastructure. Use the supplied #1/4-20 or #10-24 hardware for attaching it to the mount and note the orientation of the mounting plate with the large hole towards the front of the dock.

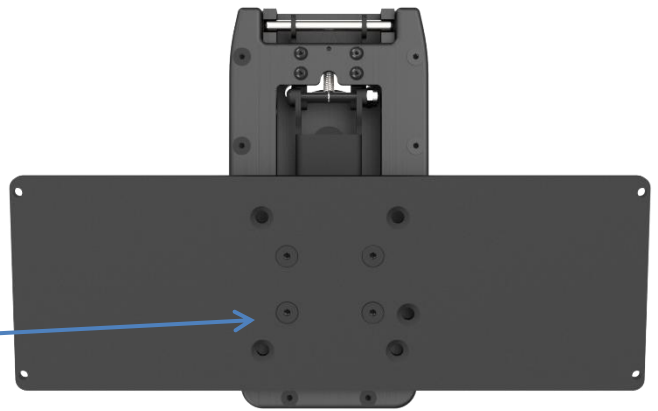

Attach the mounting bracket to the dock using the 4 supplied #10-24 UNC screws as shown above (after attaching the mounting plate to mount).

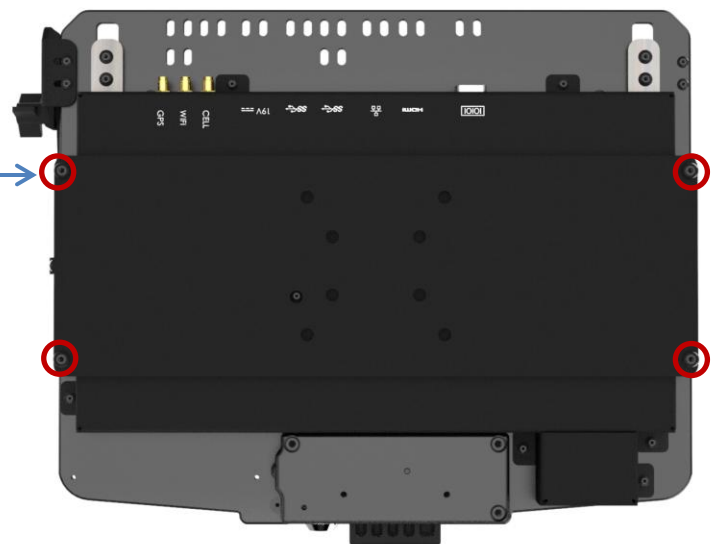

Double check all connections and hardware for proper function and tension before deploying.

Regulatory Certification Information

Regulatory Model #: AS7.G360.102

Certifications and test standards:

EN ISO / IEC 17050-1:2004

CSA C22.2 NO. 62368-1

UL 62368-1

ICES-003(A) / CISPR 32 / EN 50498

MIL-STD-810H

RoHS(2011/65/EU)

Made in Canada

This device complies with Part 15 of the FCC Rules. Operation is subject to the following two conditions. (1) this device may not cause harmful interference, and (2) this device must accept any interference received, including interference that may cause undesired operation.



www.gamberjohnson.com

1-800-456-6868 | sales@gamberjohnson.com

Gamber-Johnson World Headquarters

5001 Joerns Drive, Stevens Point, WI 54481, USA